

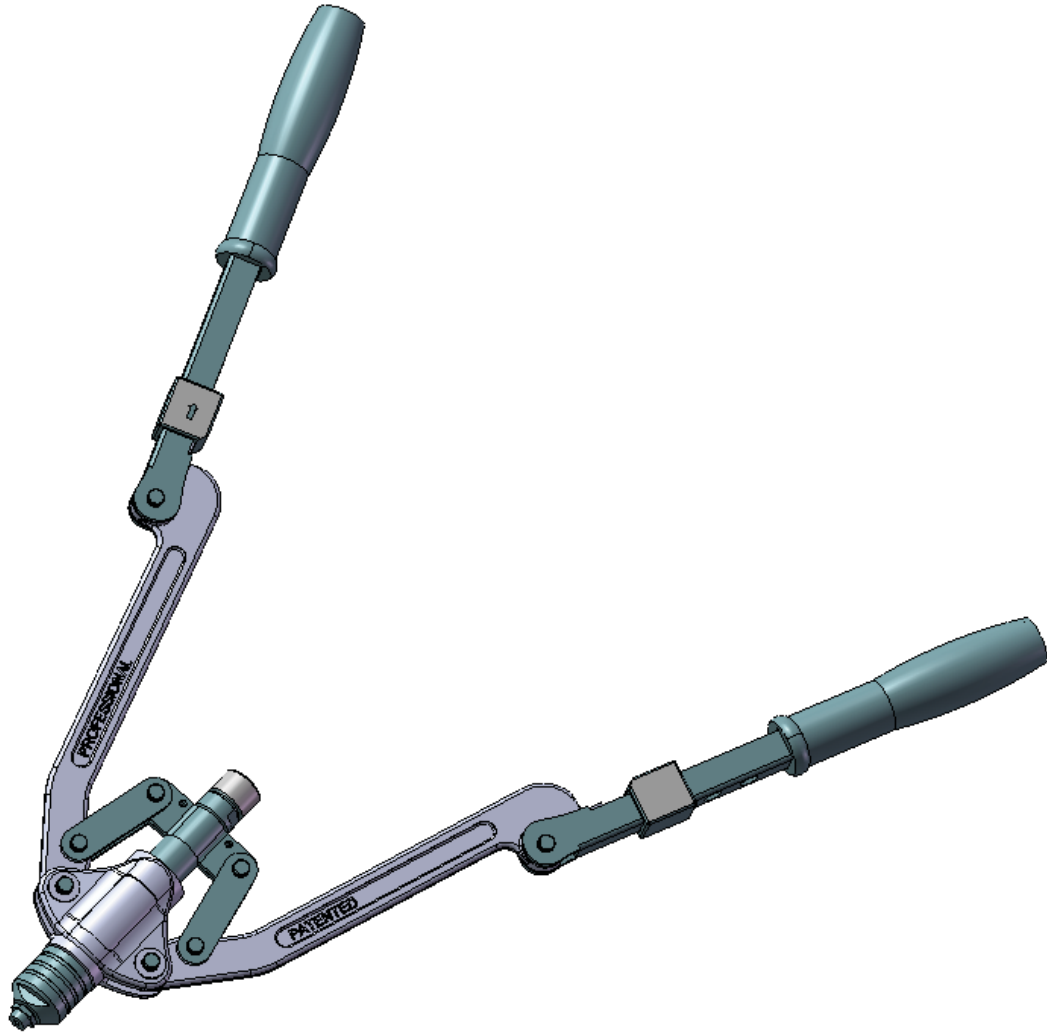

User Instruction Manual
Model# RK21
RK21-M



FOR SALES, SERVICE OR TECH SUPPORT CALL:
1800-BUY-RIVET or 1-800-289-7483

CONTENTS

Safety	Page 3
Specifications	Page 3
Jaw Maintenance and Replacement	Page 4
Conversion to Blind Rivets	Page 5
Conversion to Rivet Nuts	Page 6
To Install Rivet Nuts	Page 7
To Install Rivet Blind Rivets	Page 8
Schematic	Page 9
Troubleshooting	Page 10
Warranty	Page 11

SAFETY

- ➡ DO NOT USE OUTSIDE DESIGN INTENT OR WITH EQUIPMENT THAT IS NOT RECOMMENDED BY THE MANUFACTURER.
- ➡ DO NOT OPERATE A TOOL THAT IS DIRECTED TOWARDS ANY PERSON(S) OR WITH THE MANDREL CATCHER OFF THE TOOL
- ➡ ALL MODIFICATIONS CARRIED OUT ON THE TOOL WITHOUT EXPRESS WRITTEN CONSENT OF THE MANUFACTURER SHALL BE DONE SO AT THE CUSTOMERS' SOLE RESPONSIBILITY
- ➡ REFER TO THIS MANUAL BEFORE ATTEMPTING ANY MAINTENANCE OPERATION. DO NOT DISASSEMBLE THIS TOOL BEFORE REFERRING TO THIS MANUAL.
- ➡ AVOID EXCESSIVE CONTACT WITH LUBRICANT, AS SOON AS POSSIBLE WASH HANDS THOROUGHLY
- ➡ INSPECT THE TOOL USING PREVENTITIVE MAINTENANCE TECHNIQUES AT REGULARLY SCHEDULED INTERVALS. INSPECT FOR DAMAGE AND FUNCTION BY TRAINED COMPETENT PERSONNEL. REPLACE COMPONENTS WHENEVER THERE IS EVIDENCE OF IMPACT DAMAGE, CHIPPING, OR CRACKING.
- ➡ WEAR SAFETY GLASSES AND ADOPT FIRM FOOTING DURING OPERATION.

SPECIFICATIONS

The specifications and information contained in this manual are applicable only to the tool with which it was supplied. Industrial Rivet & Fastener Co reserve the right to make any changes without notice as part of Industrial Rivet & Fastener Co policy of continuous improvement.

SPECIFICATIONS FOR RK-21 RIVET TOOL			
Model#	Description	Rivet Nuts	Rivets
RK21	Inch Tool	#8-32, #10-32, 1/4-20", 5/16"-18, 3/8-16"	1/8", 5/32", 3/16", 1/4"
RK21-M	Metric Tool	M4,M5, M6, M8, M10	3.2, 4.0, 4.8, 6.4
	Purchased Separately	#6-32, 10-24, 1/4-28", 5/16"-24, 3/8-24 Metric: M4,M5, M6, M8, M10	Monobolt Nose Piece

1) Remove Nose Piece barrel using wrench provided.

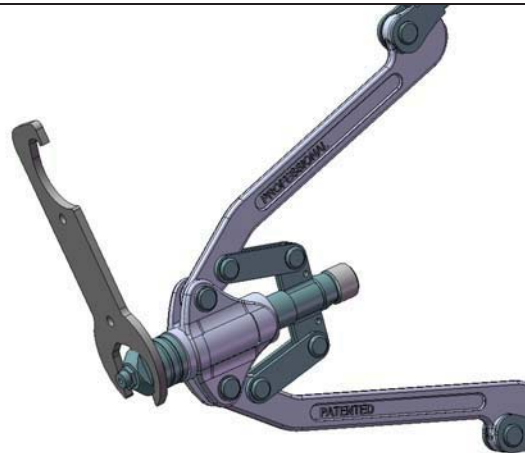

2) Remove Jaw Case using 2 wrenches provided by securing the mandrel lead and removing the jaw case.

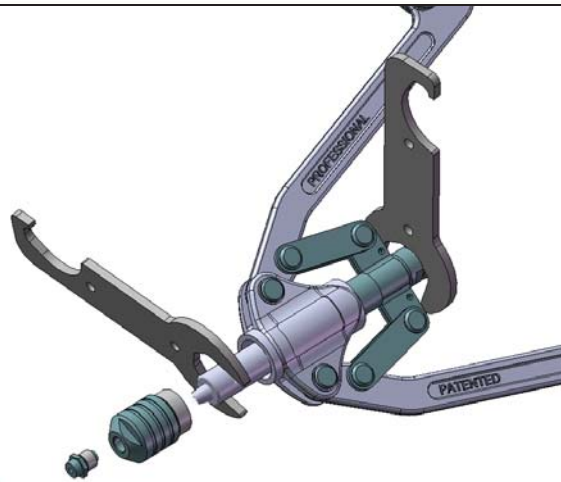

3) Remove the threaded male plug with a slotted screw driver. This will expose the Jaws. Check the jaws for wear, clean and replace if necessary. Check the spring compression and leading edge of the jaw pusher and replace if necessary. Reassemble according to this drawing. Reassemble the tool in reverse order.

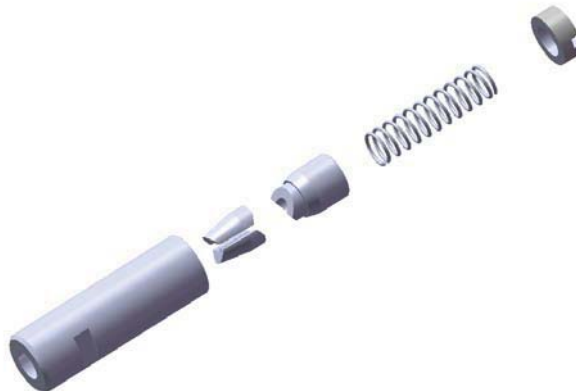

1) Remove Nose Piece barrel using wrench provided. Store the nose piece barrel and nose piece in the blow mold case for future use.



2) Remove Jaw Case using 2 wrenches provided by securing the mandrel lead and removing the jaw case. Store all removed components in the blow mold case for future use.

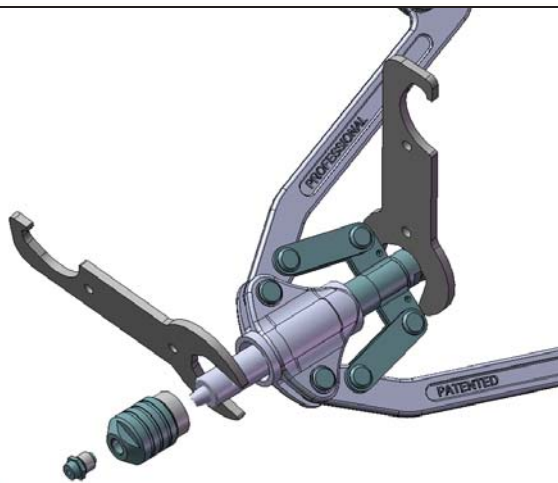

4) In the blow mold box, find the rivetnut nose adapter. Thread this piece into the body of the tool securely using the wrenches provided. Then select the rivet nut thread size and the corresponding mandrel (the thread size is stamped on the side of the mandrel). Install the mandrel into the tool body using the wrench provided. Select the nose piece which fits most snug to the selected mandrel. Find the hex nut which fits the nose piece and install it on the nose piece (it may be fitted onto another nose piece size). Install the nose piece fitted with the hex nut into the body of the tool using the wrenches provided. Set the desired stroke of the tool with this hex nut.

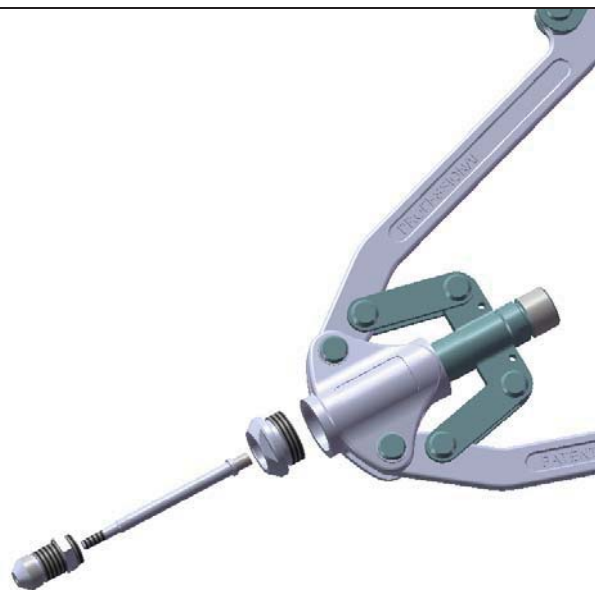

- 1) Loosen hex nut and remove nose piece with the wrenches provided. Store in the blow molded case for future use. Remove the rivet nut nose adapter and mandrel with wrench provided and store in the blow molded case for future use.



- 2) Install Jaw Case Assembly using 2 wrenches provided by securing the mandrel lead and removing the jaw case. Tighten to secure the connection. Then install the blind rivet nose adapter onto the tool body.

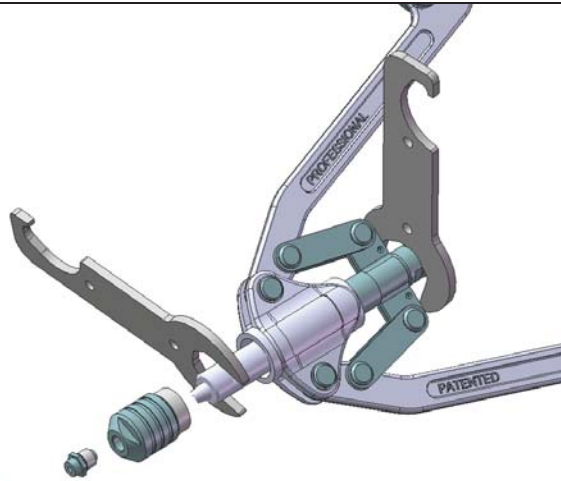

- 3) Then select the nose piece according to the desired rivet to install and tighten using the wrench provided. The sizes are stamped on the side of the nose pieces.

3.2 = 1/8"
4.0 = 5/32"
4.8 = 3/16"
6.4 = 1/4"

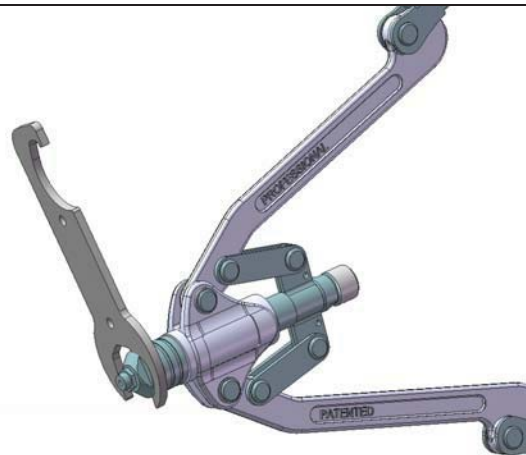

- 1) Insure mandrel size is fit for the rivetnut size you wish to install.
- 2) Adjust the nose piece so that the rivet nut (when threaded on to the mandrel), is flush with the mandrel while the handles are in the open position.
- 3) Tighten the locknut in place to secure the connection

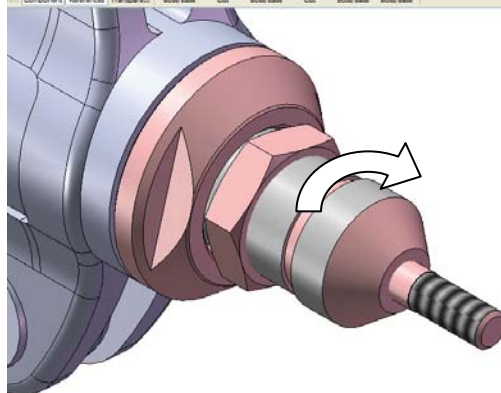

- 1) Prepare the rivet nut by either spinning the rivet nut onto the mandrel or by rotating the mandrel lead to thread the rivet nut onto the tool. Make sure the handles are in open position.
- 2) Install the rivetnut in the hole and close the handles with even pressure to fasten the rivet nut.
- 3) Unthread the tool by rotating the mandrel lead to release the tool from the nut.

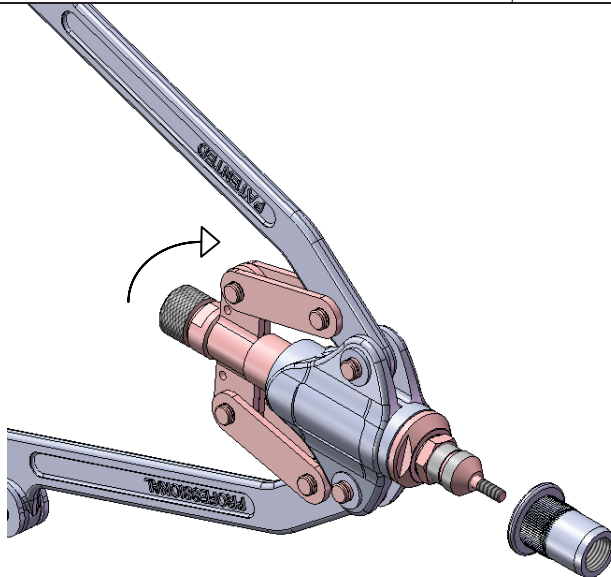

WARNING!!!!

Do not overtighten the rivetnut as it could result in stripped rivetnut threads or a damaged mandrel

1) Then select the nose piece according to the desired rivet to install and tighten using the wrench provided. The sizes are stamped on the side of the nose pieces.

- 3.2 = 1/8"
- 4.0 = 5/32"
- 4.8 = 3/16"
- 6.4 = 1/4"

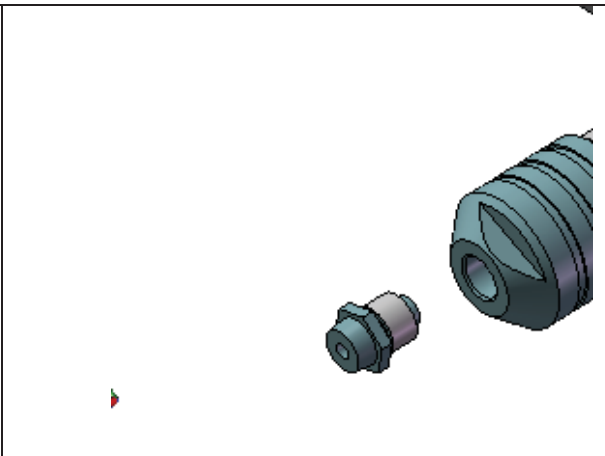

- 4) Open the handles
- 5) Put the rivet into the nose piece
- 6) Close the handles with even pressure to apply the rivet.
- 7) If the rivet does not snap, open the handles and allow head of the rivet to touch the nose piece again. Then repeat step 5 (and step 6 if necessary)
- 8) When the rivet snaps, open the handles completely so that the nail falls freely from the tool.
- 9) If a mandrel is jammed, proceed to the "JAW REPLACEMENT AND MAINTENANCE" section

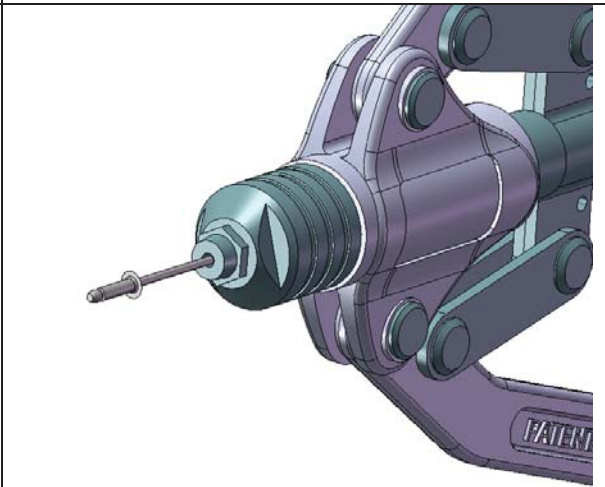

WARNING!!!!

Spent nails on the floor pose a hazard to workers as they may slip, fall and possibly injure themselves. Dispose of spent mandrels properly.

SCHEMATIC

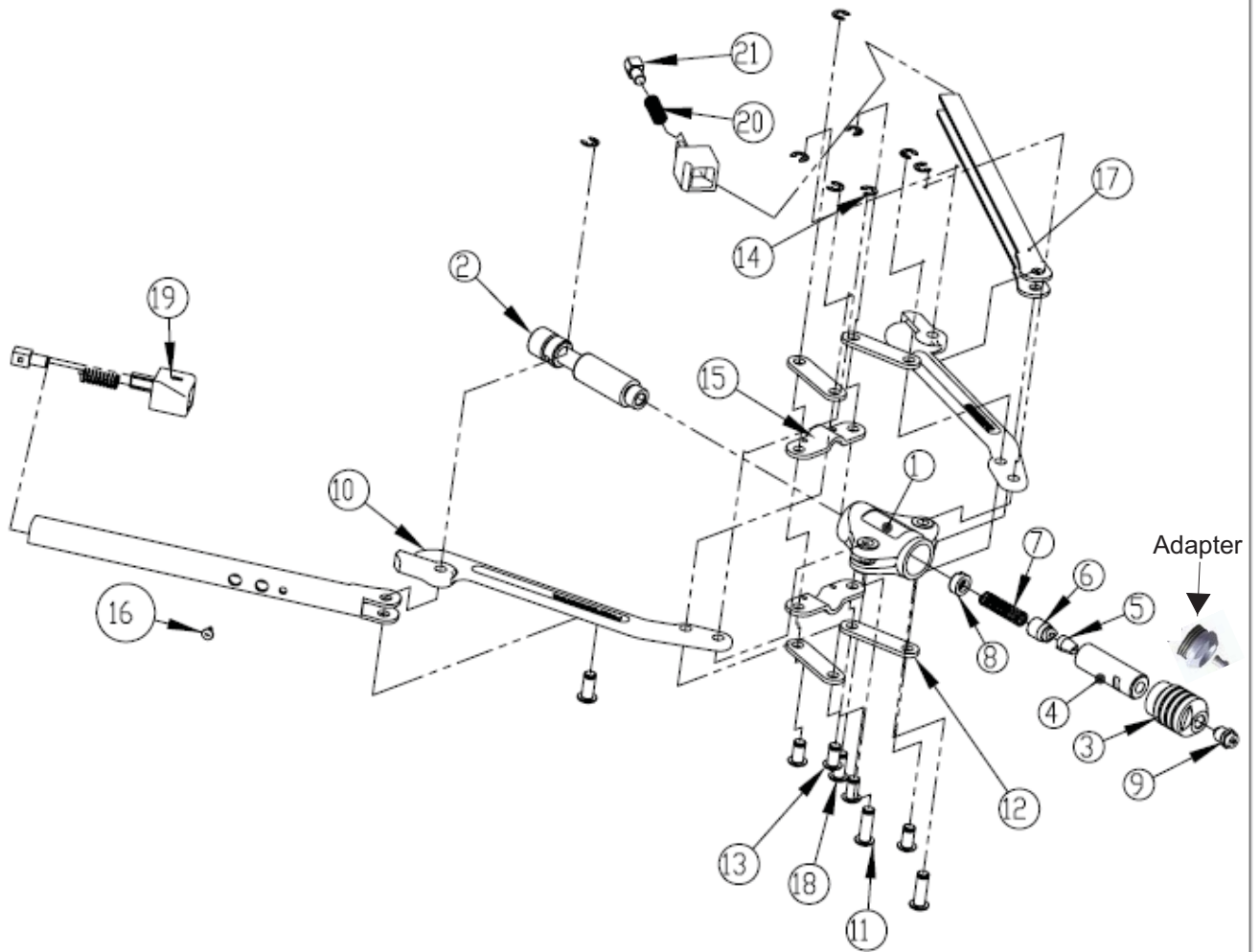

RIVETKING

Part#	Description	Part#	Description
1	Body Frame	11	Body Pin
2	Draw Bar Lead	12	Connecting Bar
3	Sleeve Seat	13	Bar Pin
4	Jaw Case	14	E-6 Ring
5	Jaws	15	Balancing Bar
6	Jaw Pusher	16	Screw
7	Press Spring	17	Handle
8	Spring Screw	18	Handle Pin
9	Nose Piece	19	Handle Lock
10	Lever	20	Handle Lock Spring
		21	Lock Spring Stopper

TROUBLESHOOTING

Item numbers in parentheses refer to assembly drawing part numbers on page 9.

Problem	Possible Cause	Remedy
Blind Rivet - Jaws will not release broken stem of fastener	<ul style="list-style-type: none"> ▪ Wrong Nose Piece ▪ Tool Handles not opened completely ▪ Jaws are Jammed 	<ul style="list-style-type: none"> ▪ Replace with a snug fitting nose piece or according to the rivet diameter. ▪ Open tool handles completely, with force if necessary. ▪ Follow Jaw Maintenance/Replacement Procedure
Tool will not grip stem of fastener	<ul style="list-style-type: none"> ▪ Worn or broken jaws ▪ Build up of dirt inside the nose assembly ▪ Loose jaw housing ▪ Weak or broken spring in nose assembly ▪ Incorrect component in nose assembly 	<ul style="list-style-type: none"> ▪ Fit new jaws ▪ Service nose assembly ▪ Tighten against locking ring ▪ Fit new spring ▪ Identify and replace
RivetNut – RivetNut will not thread onto mandrel	<ul style="list-style-type: none"> ▪ Wrong Mandrel Size ▪ Damaged Mandrel Threads ▪ Damaged RivetNut Threads 	<ul style="list-style-type: none"> ▪ Check to make sure the rivetnut you are using is not metric or of a different thread pitch of the mandrels provided with the tool. If a different thread size or pitch is needed, contact sales department. ▪ Replace Mandrel, contact sales department for replacement. ▪ Discard and replace rivetnut.
Mandrel will not release the rivetnut	<ul style="list-style-type: none"> ▪ To much pressure was applied during the setting process ▪ RivetNuts are too soft 	<ul style="list-style-type: none"> ▪ Disengage the nut from the mandrel and disassemble the tool and remove the mandrel from the tool if necessary. Review "Setting Rivetnuts" ▪ Contact fastener distributor for replacement lot of rivetnuts.

Warranty Statement:

Industrial Rivet & Fastener Co. Inc. (hereinafter "IRF"), hereby warrants to the initial retail customer and original distributor ("Warrantee") only that its products will be free from defects in material and workmanship for a period of 1 year from the purchase date, provided that the products are used in accordance with "IRF's" instructions as to maintenance, operation and use.

The said warranty does not extend to goods subjected to misuse, neglect, accident or improper installation or maintenance or which have been altered or repaired by anyone other than the seller or its authorized agents.

The warrantee's only remedy and IRF's only obligation in the event of a defect or failure in the products, is that IRF, at its sole option, repair, replace or rework the products, but in no case shall the cost of the foregoing exceed the invoice price of the products.

This warranty shall be void if any person seeking to make a claim for defective or failed products fails to notify IRF within 30 days of receipt of evidence that the product is defective or has failed, or if said person fails to provide IRF with such evidence as is reasonably requested concerning the effect or failure, including without limitation, evidence of the date of purchase and date of installation.

This warranty is in lieu of all other warranties, expressed or implied, including merchantability, or fitness provided for herein. Under no circumstance shall IRF be liable for incidental or consequential damages arising from the defect or failure in its products.

Seller's sole obligation under the foregoing warranty will be limited to, at Seller's option, repair or replacement of the tool (and shipping to the buyer with transportation charges paid to any place within the contiguous 48 states). Returned goods will be evaluated by our warranty repair department and a conclusion will be determined and classified as:

- a) Warranty Repair (free of charge)
- b) Abuse /Neglect (bench fee and/or hourly rate)
- c) Maintenance (Flat Fee)

Price Schedule as of 1/1/2007

Bench Fee: \$55.00

Hourly Rate: \$55.00 per hour

Flat Fee:

Level 1 - Adjustments and light repair \$35.00 + parts

Level 2 - Maintenance, \$55.00 + parts

Level 3 - Overhaul, complete disassembly, \$85.00 + parts

If inspection by the seller of returned goods shows no breach of the forgoing warranty, Seller's regular conditioning charges (as stated above) apply. Upon this conclusion we will either repair the tool at no cost to you and return it postage paid, or call you to inform you of the repair cost. The repair will need to be approved in writing before any work is performed.

A comprehensive tool service and repair program, for details contact your local area sales representative or call:

Industrial Rivet & Fastener Co.
200 Paris Ave
Northvale, NJ 07647
1-800-BUY-RIVET