



Your One Source

The deepest
inventory of rivets.

The most
innovative
delivery systems.



RivetKing® - For Everything You Need

As a world-class manufacturer, distributor and importer – RivetKing® gives you access to the industry's deepest inventory of ready-made rivets. Our extensive knowledge of permanent fasteners and extensive manufacturing network also means we can make custom products in any head style, length, material and finish, including:

- Blind rivets
- Speed rivets
- Rivet nuts
- Solid rivets
- Semi-tubular rivets
- Split rivets
- Shoulder rivets
- Collar rivets
- Drive rivets
- LockBolts

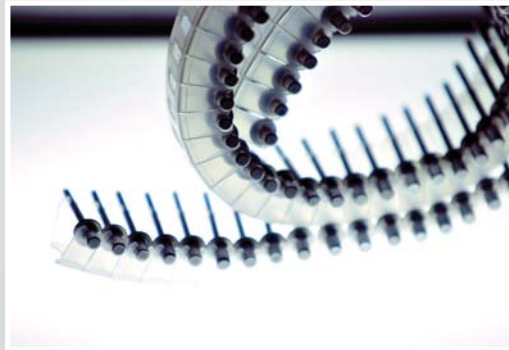

All this is combined with a wide array of innovative rivet delivery systems, including our groundbreaking KingSet™ handheld tool.

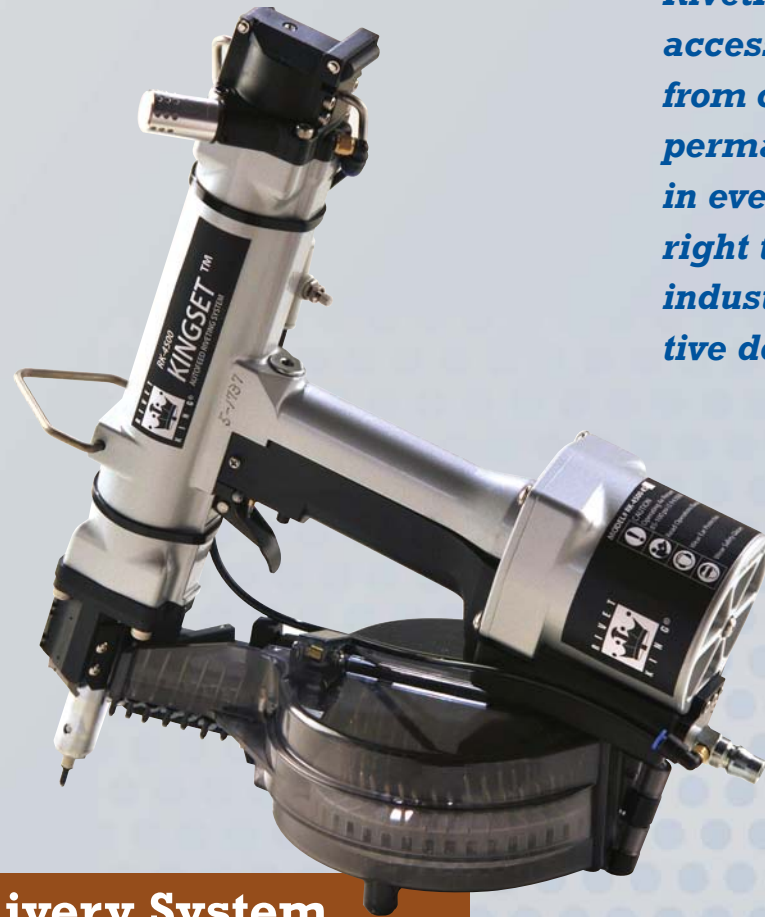

RivetKing provides access to everything from custom and in-stock permanent fasteners in every type and size, right through to the industry's most innovative delivery systems.

Personalized Service and Support

With ten international locations, 11 U.S. distribution centers and nearly 50 employees – RivetKing is uniquely positioned to deliver a superior and innovative product set backed by exemplary service and unmatched quality. When you choose KingSet, our Application Engineers will conduct an in-depth evaluation of your operations and make recommendations on how this automated, handheld tool can best work in your environment. In addition, experts are always available by phone or onsite to provide technical support for any product; even another manufacturer's current and past rivet delivery systems.

Simply put, KingSet gives you all the reliability you are used to, but with a far greater range of applications with the ability to use our self-feed riveting system with any manufacturer's rivets.



KingSet streamlines the assembly of sheet metal fabrications including appliances, automotive products, electronic chassis, outdoor signage, HVAC and more.



KingSet™ – A Revolutionary Rivet Delivery System

KingSet™ is a sophisticated handheld riveting system offering users a truly unprecedented level of functionality.

With auto-feed capabilities – KingSet can literally be used to set any type of 1/8", 5/32" and 3/16" breakstem blind rivet pre-loaded on tape. And since KingSet has been engineered and designed for different application ranges, it can easily adapt to a variety of manufacturing environments.

The incredible flexibility of our best-in-class rivet delivery system also provides a fast setting operation that includes rapid reload and cycle times. The result is an immediate increase in productivity and significant cost savings with the reduction of in-place installation. For even greater efficiency, an adjustable vacuum system minimizes air

consumption based specifically on the size of the rivet being set.

KingSet is a fully portable, ergonomically balanced tool that can be suspended either horizontally or vertically. This is combined with a highly engineered, one-touch operation that allows users to set rivets automatically while leaving one hand free to hold work pieces in place. Plus, a built-in Mandrel Collection System (MCS) helps insure work place safety and cleanliness.

Perfect for mid-range to high volume applications, KingSet provides a strong, reliable joint while effectively streamlining the assembly of everything from appliances, to automotive products, to electronic chassis, to HVAC and other sheet metal fabrications.

Put RivetKing and KingSet to Work for You

When you work with RivetKing, you will quickly see we are far more than a supplier. We are, in fact, your business partner – one that can deliver virtually any type of rivet you might need, as well as the delivery system that provides unmatched reliability and flexibility while also increasing your productivity.

Let us tell you more about the range of applications KingSet can handle and show you first hand what RivetKing can do for you and your customers. Call us today for a quote or evaluation.

Industrial Rivet & Fastener Company

200 Paris Avenue
Northvale, NJ 07647
1-800-289-7483 (1-800-BUY-RIVET)
201-750-1040
Fax: 201-750-1050
E-mail: info@rivet.com

Find Us Online

You can access our catalog online at:
www.rivet.com

Benefits at a Glance

Auto-Feed

- Pre-loaded rivets on tape

Fast Operation

- Reload time: 8-10 seconds
- Cycle time: 2 seconds

Easy-to-Use

- One-touch cycle
- Built-in MCS
- Adjustable vacuum

Portable

- One free hand
- Ergonomically weight balanced

Reliable

- Three jaw system
- Longer maintenance interval

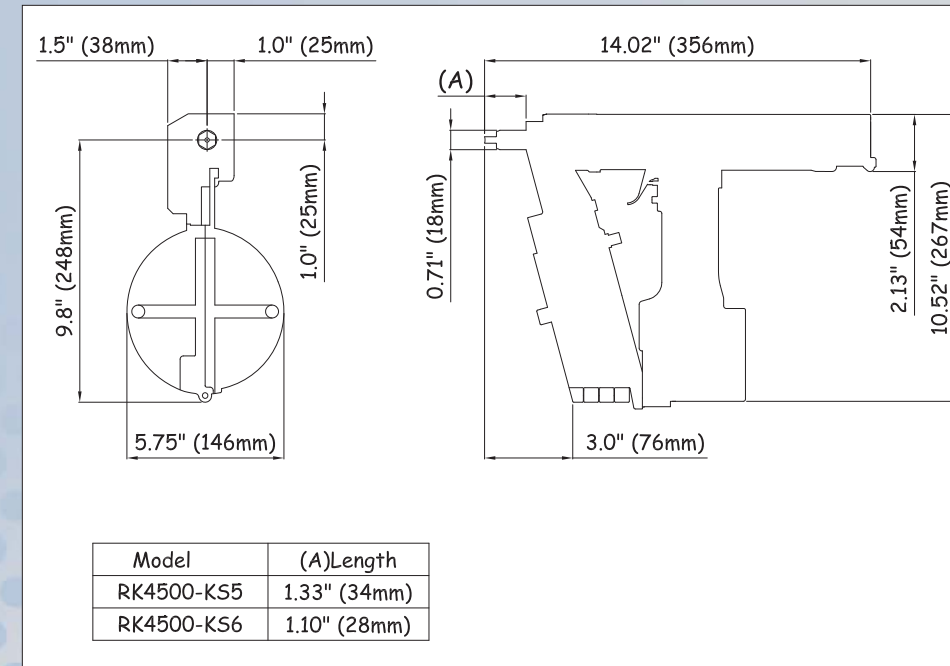

Industrial Rivet & Fastener Company

200 Paris Avenue
 Northvale, NJ 07647
 1-800-289-7483
 (1-800-BUY-RIVET)
 201-750-1040
 Fax: 201-750-1050
 E-mail: info@rivet.com

Find Us Online

You can access our catalog online at:
www.rivet.com

RivetKing	ABA Aluminum/Aluminum			ABS Aluminum/Steel			SBS Steel/Steel			FBS Steel/Stainless			FBF Stainless/Stainless		
	1/8"	5/32"	3/16"	1/8"	5/32"	3/16"	1/8"	5/32"	3/16"	1/8"	5/32"	3/16"	1/8"	5/32"	3/16"
Open End	Blue	Blue	Blue	Blue	Blue	Blue	Blue	Blue	Blue	Blue	Blue	Blue	Blue	Blue	Blue
Closed End	Blue	Blue	Blue	Blue	Blue	Blue	Blue	Blue	Blue	Blue	Blue	Blue	Blue	Blue	Blue
Multigrip CT™	Blue	Blue	Blue	Blue	Blue	Blue	Blue	Blue	Blue	Blue	Blue	Blue	Blue	Blue	Blue
Multigrip RT™	Blue	Blue	Blue	Blue	Blue	Blue	Blue	Blue	Blue	Blue	Blue	Blue	Blue	Blue	Blue
RK-Q®	Blue	Blue	Blue	Blue	Blue	Blue	Blue	Blue	Blue	Blue	Blue	Blue	Blue	Blue	Blue
RIVEX®	Blue	Blue	Blue	Blue	Blue	Blue	Blue	Blue	Blue	Blue	Blue	Blue	Blue	Blue	Blue
Rivibulb®	Blue	Blue	Blue	Blue	Blue	Blue	Blue	Blue	Blue	Blue	Blue	Blue	Blue	Blue	Blue
Rivinox®	Blue	Blue	Blue	Blue	Blue	Blue	Blue	Blue	Blue	Blue	Blue	Blue	Blue	Blue	Blue
Gentleset™	Blue	Blue	Blue	Blue	Blue	Blue	Blue	Blue	Blue	Blue	Blue	Blue	Blue	Blue	Blue
Easy Entry	Blue	Blue	Blue	Blue	Blue	Blue	Blue	Blue	Blue	Blue	Blue	Blue	Blue	Blue	Blue
Grooved Rivets	Blue	Blue	Blue	Blue	Blue	Blue	Blue	Blue	Blue	Blue	Blue	Blue	Blue	Blue	Blue
PLR Rivets™	Blue	Blue	Blue	Blue	Blue	Blue	Blue	Blue	Blue	Blue	Blue	Blue	Blue	Blue	Blue
TriFix®	Blue	Blue	Blue	Blue	Blue	Blue	Blue	Blue	Blue	Blue	Blue	Blue	Blue	Blue	Blue
Inlock® Structural	Blue	Blue	Blue	Blue	Blue	Blue	Blue	Blue	Blue	Blue	Blue	Blue	Blue	Blue	Blue
Tigerbolt® Structural	Blue	Blue	Blue	Blue	Blue	Blue	Blue	Blue	Blue	Blue	Blue	Blue	Blue	Blue	Blue

■ Approved for use with KingSet® (600 maximum rivet body length)

■ Application testing required, subject to RivetKing Design Engineers' approval

■ Not recommended for use with KingSet®

■ Not Applicable