

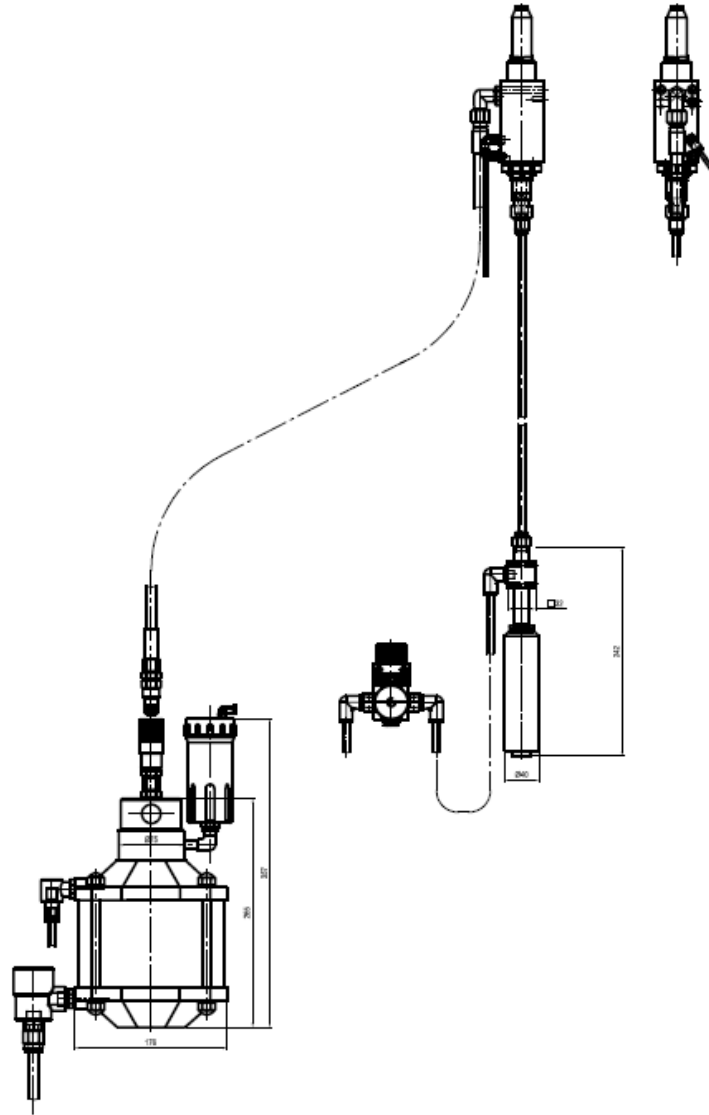

Instruction Manual Riveting System RK-P3MBx105



For sales, service or support call your local distributor or:

1 800-BUY-RIVET or 1-800-289-7483 www.rivet.com











CONTENTS

	PAGE
Contents	2-3
Symbols	4
1 Safety instructions	5-6
2 General data	
2.1 Warranty/liability	7
2.2.1 Responsibility of the operator	7
2.2.2 Personnel requirements	8
2.3 Manufacturer / contact	8
2.4 Document notes	9
3 Technical data	
3.1 Riveting module	10
3.2 Riveting module	11
3.3 Riveting equipment	12
3.4 Pressure intensifier	13
4 Description	
4.1 Use	14
4.1.1 Intended use	14
4.1.2 Inappropriate use	14
4.2 Construction of the riveting module	15
5 Getting Started	
5.1 Transportation and storage	16
5.2 Installation	16
5.2.1 Mounting riveting module type RK-P3MBX105	17
5.2.2 Mounting pressure intensifier	17
5.2.3 Installation protective equipment	18
5.3 Supply lines	18
5.3.1 Connecting Pneumatic hoses (rear hub / riveting module)	18-19
5.3.2 Connect Pneumatic hoses (vacuum nozzle / customer pneumatic - control)	19
5.3.3 Connecting hydraulic hose	20-21
5.4 Setup	21-22
5.4.1 Set pressure intensifier	22
5.4.2 Control	22





CONTENTS

	PAGE
6 Operation	
6.1 Operation	23
6.1.1 Riveting module in operation	23-24
6.1.2 Riveting module decommission	24
6.2 Operation	24
6.2.1 Operation process	24
7 Maintenance	
7.1 Maintenance intervals	25-26
7.2 Changing the riveting equipment	27-28
7.3 Venting riveting module	28-29
7.4 Errors	30
7.5 Spare parts	31
7.5.1 Spare parts mandrel broken riveting module	32
7.5.2 Spare parts list mandrel broken riveting module	33
8 Disposal	
8.1 Disposal	34
8.2 Procedure	34
8.3 Additional	34
9 Certificate	
Declaration of incorporation of partly completed machinery (Machinery directive 2006/42/EC)	35
Assembly instructions pursuant to annex VI (Machinery directive 2006/42/EC)	36
10 Third-party documentation	
10.1 Pressure intensifier	37
11 Drawings	
11.1 Riveting module cpl.	48
11.2 Riveting module assy. Type RK-P3MBX105	50
11.3 Rivet mandrel suction cpl.	52
11.4 Pressure intensifier cpl.	54



SYMBOLS

	<p><i>A warning triangle together with the signal word "WARNING" indicates a potentially hazardous situation, which if not avoided can lead to severe injury or death.</i></p>
	<p><i>A warning triangle together with the signal word "CAUTION" indicates a potentially hazardous situation, which if not avoided can lead to moderate to severe injury.</i></p>
	<p><i>A symbol with the signal word "NOTICE" indicates additional information that should be observed when handling the riveting module or its components.</i></p>
	<p><i>This symbol denotes key information for a better understanding of the machine's operating processes instead of safety instructions.</i></p>
	<p>Eye protection required (BGV A8 - M01)</p>
	<p>Switch off before proceeding (BGV A8 - M14)</p>
	<p>Protective gloves required (BGV A8 - M06)</p>
	<p>Dispose of in recycling.</p>
	<p>Worn out tools must be disposed of according to the regional guidelines. Residual waste disposal prohibited.</p>
	<p>Cross reference (see also...)</p>

1. Safety Instructions

	<p><i>The following safety instructions must be followed during the installation, operation, maintenance and any dealings with riveting module!</i> <i>Failure to comply can lead to injury!</i></p>
	<p><i>The following safety instructions must be followed during the operation and any handling of the riveting module!</i> <i>Failure to comply can lead to personal injury.</i></p> <ul style="list-style-type: none"> • <i>The riveting module must not be operated without the safety guard!</i> • <i>The riveting module must not be operated without complete rivet equipment.</i> • <i>Do not use rivet application during riveting!</i> • <i>The operating pressure must not exceed 6 bar.</i>
 	<p><i>Prior to any repair or maintenance work, the riveting module must be disconnected from all supply lines to prevent it from turning on!</i></p>
	<p><i>The following safety instructions must be followed during the operation and any handling of the riveting module!</i> <i>Failure to comply can lead to personal injury.</i></p> <p>Maintenance of the riveting module</p> <ul style="list-style-type: none"> • <i>The riveting module must be maintained so that it complies with the applicable accident prevention and safety regulations at any time and safe operation is guaranteed.</i> <p>Using spare parts / attachment of ancillary equipment</p> <ul style="list-style-type: none"> • <i>Use of spare parts or ancillary equipment that are not approved by the manufacturer, it may cause damages to occur. Only spare parts from our spare parts list or parts released by us for the riveting module should be used. The attachment of additional equipment must be approved by P3.</i> <p>Risk of injury due to crushing. Prior to any repair and maintenance work on the pneumatic components and interconnections, make sure they are disconnected from the compressed air supply.</p> <ul style="list-style-type: none"> • <i>Work on the components and interconnections may be carried out only by qualified personnel, taking into account the information in the operating instructions.</i> <p>Risk of injury due to crushing. Before any repair and maintenance work on hydraulic components and interconnections, they must be depressurized.</p> <ul style="list-style-type: none"> • <i>Work on the hydraulic components and interconnections may be carried out only by qualified personnel, taking into account the information in the operating instructions.</i>

1. Safety Instructions

	<i>Always wear eye protection when on site of the riveting module.</i>
	<i>Safety gloves must be worn when working with sharp-edged components.</i>
NOTICE	<i>The riveting module must only be operated by suitably trained personnel. The relevant accident prevention guidelines must be followed!</i>
	<i>This operating manual is to be kept at the place of use of the riveting module and kept legible to the operator.</i>
	<i>The riveting module is to be used only for the intended purpose. (↻ Description - purpose)</i>
	<i>If you have questions regarding the system and user safety, please contact Industrial Rivet for more information.</i>

2. General

2.1 Warranty / liability

In principle, the **General terms and conditions** of Industrial Rivet & Fastener apply. These are available to the customer when the contract is concluded. Warranty and liability claims for injury and damage to property are excluded if it is due to one or more of the following reasons:

- Use of the riveting module for an improper purpose.
(↪ *Description - purpose*)
- Improperly performed installation, commissioning, operation, repair or maintenance of the riveting module.
- Operation of the riveting module despite defective, improperly installed or non-functioning safety or protective equipment.
- Structural change without express written confirmation by Industrial Rivet & Fastener.
- Inadequate monitoring of parts that are subject to wear.
- Improperly carried out repairs or maintenance of riveting module.
- Catastrophe cases due to exposure to foreign bodies or extreme force.

2.2.1 Responsibility of the operator

The riveting module is a state of the art piece of machinery with advanced safety measures. However, safe operation can only be achieved if all necessary measures are taken. Safe operation is subject to due diligence of the machine operator to plan and execute these measures.

The operator must ensure that

- The riveting module is used only as intended.
- The riveting module is operated only in a faultless, functional state and only when mechanical safety devices are present.
- Required protective gear is available and used by the operating, maintenance and repair personnel.
- The operating instructions and all documents are available and in a legible format at the site of use of the riveting module. It must be ensured that all persons who are active on site of the module can read the operating instructions at any time.
- Only adequately qualified and authorized personnel are working with and repairing the riveting module.
- The personnel and all applicable occupational safety and health measures are maintained according to the operating instructions contained in these safety instructions.
- All safety and warning instructions are not removed from the product.
- National accident prevention regulations and internal company regulations are followed.

2. General

2.2.2 Personnel requirements

During any use of the riveting module the following safety instructions must be observed at all times. Failure to comply can result in life-threatening injuries, machine and other property damage as well as environmental damage.

The personnel must ensure that

- Training on the module be conducted only under the supervision of an experienced person.
- Before all personnel use the riveting module, they must read the operating instructions and confirm their understanding with their signature.
- There are no unauthorized people in the module work area.
- In addition to the Industrial Rivet operating instructions, the operating and safety instructions as defined by the Occupational Health and Safety Ordinance and the Workplace Use Ordinance must also be observed.
- The operator and the supervisors are notified of any malfunctions.
- Any damage to the riveting module is immediately reported and, in case of danger, immediately disconnected from power.
- The required personal protective gear is used.

The following work described in this manual may only be carried out by qualified personnel:

- Assembly
- Commissioning
- Operation
- Maintenance

2.3 Manufacturer

Industrial Rivet & Fastener Co.
200 Paris Avenue, Northvale NJ 07647
Phone 201-750-1040
Fax 201-750-1050
Email info@rivet.com

2. General

2.4 Document notes

The copyright © on this operating manual is owned by Industrial Rivet & Fastener. These operating instructions are only intended for the operator and their personnel. It contains regulations and notes which can neither be completely or partially duplicated, spread, or otherwise communicated without the express written permission of Industrial Rivet & Fastener Co.

Issue: **June 2017**

3. Technical Data

3.1 Riveting Module

Article Number	K 010 000 367
Working pressure (pneumatic)	maximum 6 bar
Operating pressure (hydraulic)	maximum 250 bar
Hydraulic oil	DIN EN ISO 6743-4 HLP32
Noise level	< 75 dB (A) at 1m distance
Mass	Approx. 13 kg
Functional range	Blind rivets up to 4.8 mm

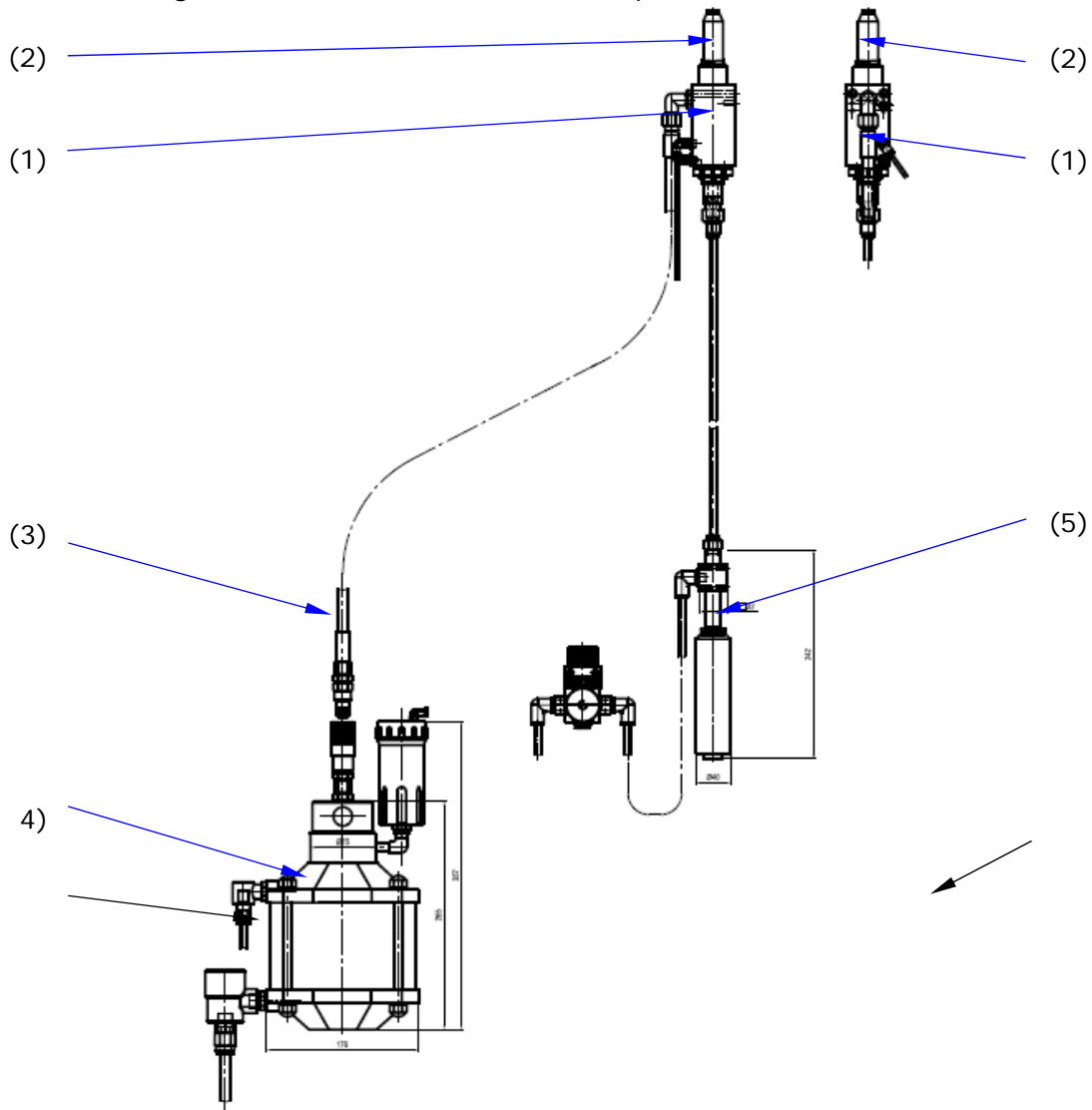

- | | |
|--|--|
| (1) Riveting module assy.
with riveting module type RK-P3MBX105 | Article No. : RK-P3MBX105-1 |
| (2) Rivet equipment (complete)
with mouth piece | Article No. : RK-P3MBX105-2
Article No. : RK-P3MBX105-
NP4.8 |
| (3) Hydraulic hose (complete). | Article No. : RK-P3MBX105-5 |
| (4) Pressure intensifier (complete). | Article No. : RK-P3MBX105-3 |
| (5) Rivet mandrel suction assy. | Article No. : RK-P3MBX105-4 |

3. Technical Data

3.2 Riveting module

Article number	RK-P3MBX105-1
Operating pressure (pneumatic) (backstroke)	max. 6 bar
Operating pressure (hydraulic)	max. 320 bar
Mass	ca. 1,2 kg
Piston stroke	max 21 mm
Oil volume	16 cm ³
Hydraulic oil	DIN EN ISO 6743-4 HLP32
Sound level	<75dB (A) at 1m distance



Parts list → 7. maintenance → 7.5.1 spare parts

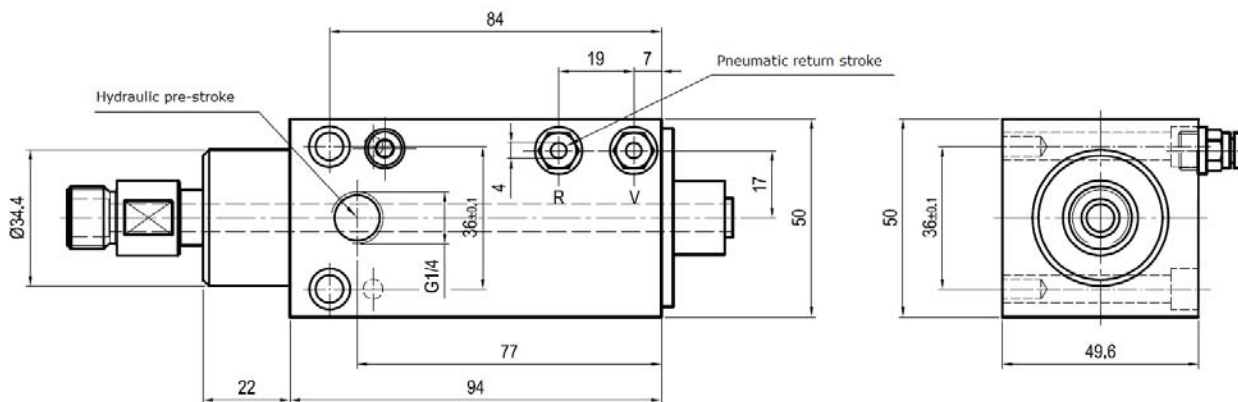

3. Technical Data

3.3 Riveting equipment

NOTICE

The riveting module is only to be used for its intended purpose.

The riveting equipment model RK-P3MBX105-1, which includes:

Pos. - Nr.	Item No.	Description	Number	Comments
1	RK-P3MBX105-NP4.8	Mouth Piece	1	
2	RK-P3MBX105-27	Nose Casing	1	
3	RK-P3MBX105-22	Chuck Collet/Jaw House	1	
4	RK-P3MBX105-21	Chuck Jaws	1	
5	RK-P3MBX105-25	Spreader	1	
6	RK-P3MBX105-23	Buffer Disc	1	
7	RK-P3MBX105-24	Spring	1	
8	RK-P3MBX105-28	Clamping Ring	1	
9	E 020 000 613-20	O-Ring	1	

Exclusively for use with blind rivets.

Size: Ø 4.8 x 16 mm

Type Aluminum / Steel, large flange

designed **only for this purpose!**

3. Technical Data

3.4 Pressure Intensifier

Article number	RK-P3MBx105-3 Typ 160.25.05 RP
Pneumatic pressure (inlet)	max. 6 bar
Hydraulic pressure (output)	max. 246 bar
Area ratio	1:41
Hydraulic oil	DIN EN ISO 6743-4 HLP32
Oil volume	67 cm ³
Noise level	< 75 dB (A) at 1m Distance
Pneumatic connections	G3/8"
Hydraulic connections	G1/4"



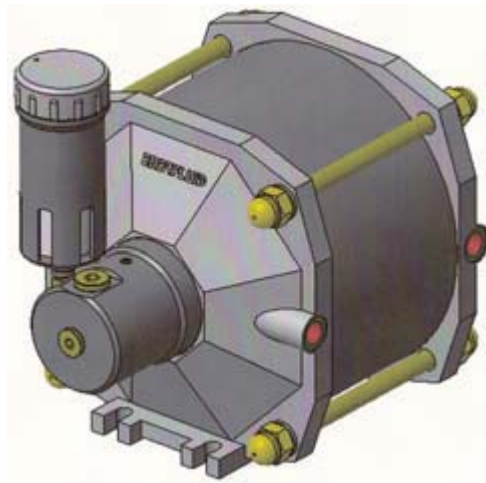

Parts List ➔ **10.1 External Documentation**



4. Description

4.1 Use

	<i>The riveting module is only to be used for its intended purpose.</i>
---	---

	<p><i>The riveting module must not be operated without the protective device (protective hood)! Failure to do so could lead to personal injury and damage to property!</i></p> <p><i>The riveting module must be integrated into the overall system in such a way that operation without the protective device is not possible. The installation of a protective device, as well as integration into a suitable safety configuration, is the responsibility of the operator.</i></p>
---	--

The riveting module is exclusively for the semi-automatic processing of blind rivets size: Ø 4.8 x 16 mm / aluminum / steel, large flange and can be used for this purpose only!

4.1.1 Intended Use

The riveting module is an incomplete machine within the definition of Directive 2006/42/EC. The riveting module is intended to be incorporated into machinery or other partly completed machinery.

Use may only occur within the specifications outlined above.

Operation is prohibited until conformity to Directive 2006/42 / EC and all other directives applicable to the installation in which the riveting module has been installed has been confirmed.

It is also necessary to observe the supplied external documentation and to observe the maintenance instructions for the intended use.

4.1.2 Warnings for Use

Any use of the riveting module beyond the intended use is considered an abuse and is not permitted.

The riveting module must not be stressed beyond its limits.

The riveting module is not suitable for use:

- ▶ In wet or moist environments of any kind (water, oils, acids, vapors, etc).
- ▶ In an environment with gases or radiation.
- ▶ In an explosive atmosphere.

4. Description

4.2 Constructing the riveting module.



When in the area and during operation of riveting module, eye protection must be worn.

The riveting module consists of a dowel riveting module and a pressure regulator with a hydraulic coupling sleeve. The riveting module is provided by the customer's hydraulic hose; With hydraulic coupling plug and with the pressure regulator. A blind rivet is set with the actuation of the pressure regulator.

The riveting module is designed for the semi-automatic processing of blind rivets sized: \varnothing 2.4 to \varnothing 6.4. By replacing the rivet equipment, it is possible to process different types of rivet sizes. The pneumatic-hydraulic pressure regulator converts a low pneumatic pressure on the primary side into a higher hydraulic pressure on the secondary side. This mode of operation makes it possible, with the aid of the relatively low pneumatic operating pressure, to operate the riveting modules with higher hydraulic pressure.

The pneumatic control of the riveting module, as well as of the intensifier is performed by the operator of the overall system.

The integration and operation of the intensifier with the riveting module into the entire system is performed by the operator of the overall system.



Rivet Equipment

Riveting Module

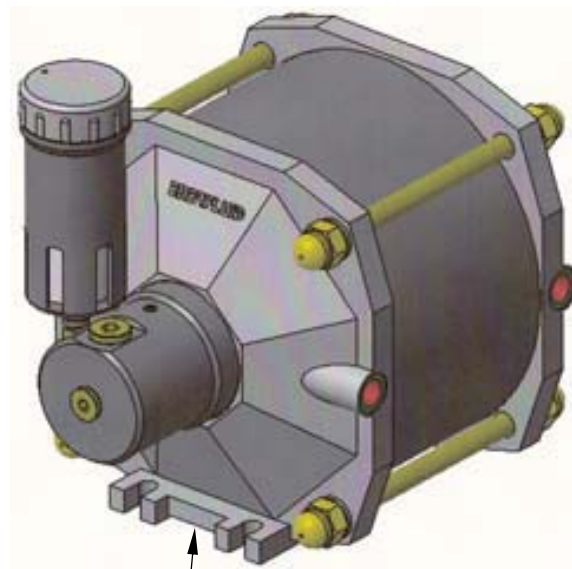

Pressure Intensifier



Pressure Intensifier → **Third-party documentation**

5. Getting Started

5.1 Transportation and Storage

Transport data

The dimensions and other data relevant to the transport of the riveting module can be found in the *Technical Data* chapter.

	<i>When transporting, loading, and unloading, ensure that the riveting module is not tilted. When transporting dangerous goods (eg oils), observe the regulations of the GGVS (Dangerous Goods Regulation Road)!</i>
---	--

The equipment is delivered in a box.

Transport damage

	<i>The customer is obliged to inspect the shipment in full upon receipt for damage and if necessary, immediately report any findings to Industrial Rivet & Fastener.</i>
---	--

If transport damage is detected, it must be documented (eg photographed) in such a way that it can be tracked later.

Storage

When storing the riveting module, make sure that the storage location is dry. Depending on the expected storage period, fragile parts must be preserved and protected against contamination.

5.2 Installation

	<i>When selecting the location, sufficient space should be considered for accessibility for maintenance and repair purposes.</i>
---	--

The choice of the installation site is the responsibility of the operator. For the riveting module, the space requirements should meet the specifications in the *Technical Data* chapter.

The riveting module consists of:

1. 1 piece riveting module
2. 1 piece pressure intensifier
3. 1 hydraulic hose
4. 1 piece rivet mandrel extractor

The Assembly, integration and commissioning of the riveting module with pressure intensifier and mandrel extraction into the entire system takes place by the operator of the overall system.

5. Getting Started

5.2.1 Mounting the riveting module type RK-P3MBx105

The riveting modules must be installed with two cap screws DIN 912-M6x55 and two cylindrical pins ISO 8734-5x12 A on the operator-side riveting module receptacles.

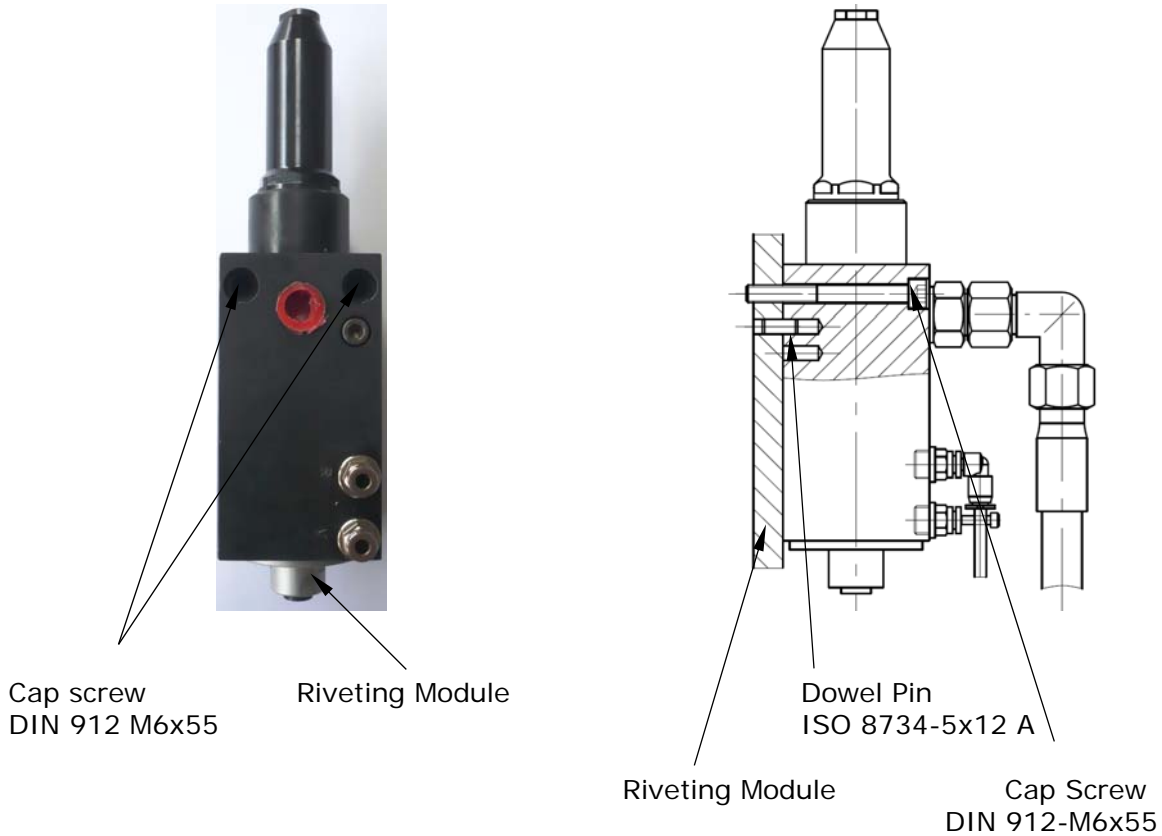

5.2.2 Mounting the pressure intensifier

The pressure intensifier must be installed with 4 M10 screws in the appropriate locations (eg wall, profile system, sub-table) of the complete system.

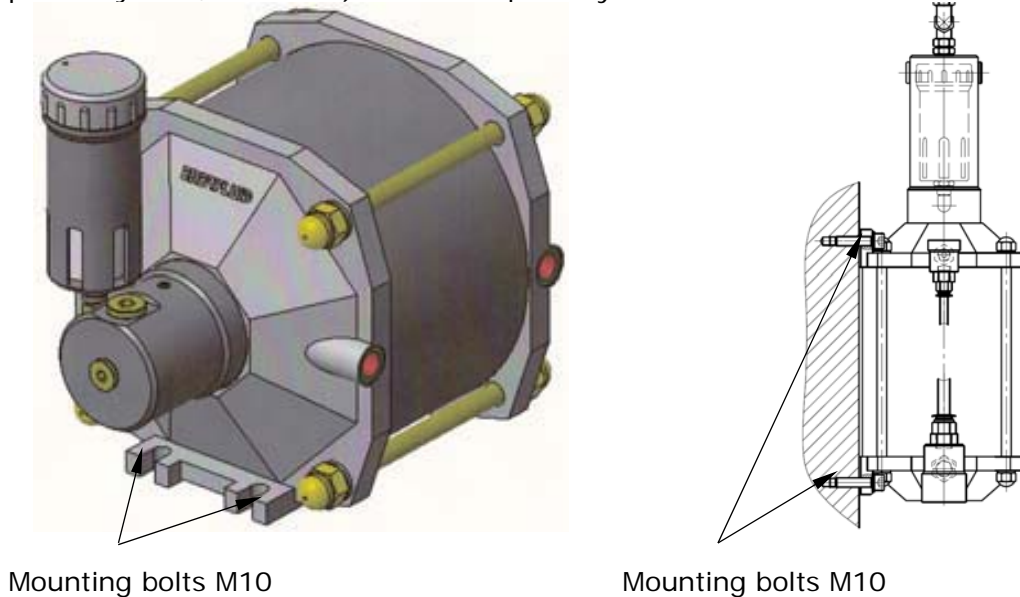

5. Getting Started

5.2.3 Mounting protective equipment (safety guard)

	<p><i>The riveting module must not be operated without a protective device (safety guard)! Failure to do so could lead to personal injury and damage to property!</i></p> <p><i>The riveting module must be integrated into the overall system in such a way that operation without a protective device is not possible. The installation location for the protective device must be chosen in such a way that there is no danger of personal injury or property damage caused by proper operation.</i></p> <p><i>The installation of a protective device, as well as integration into a suitable safety concept, is the responsibility of the operator.</i></p>
---	---

A protective device must be installed on the operator side in the center above the rivet application. The protective device must completely cover the area of the rivet application.

5.3 Supply lines

When installing the supply lines, the instructions in the chapter *Technical Data* must be followed. The tightening torques, manufacturers notes, and relevant standards must be taken into account when installing the fittings for the hydraulic hoses and pipes.

	<p><i>Do not use force when connecting! Ensure that the hoses and pipes are not kinked, crushed or otherwise damaged.</i></p>
---	--

The following supply lines are connected to the riveting module:

1. Pneumatic hoses (return stroke / riveting module).
2. Pneumatic hoses (vacuum nozzle / operator pneumatic control).
3. Hydraulic hose (riveting module / intensifier).

5.3.1 Connect Pneumatic hoses (Return stroke / riveting module)

	<p><i>The pneumatic hoses must not be placed near heat sources or in environments with intense conditions. Ensure that the pneumatic hoses are not kinked, crushed or otherwise damaged!</i></p>
---	---

	<p><i>Risk of property damage and malfunctions.</i></p> <p><i>Operate the riveting module of min to a maintenance unit G3/8 (Filter / regulator) with dry unlubricated compressed air!</i></p>
---	---

The return stroke connection of the module is equipped with a PU plastic hose of the nominal size 4 to the operator-side pneumatic control.

Ensure that a sufficient inlet pressure of minimum 6 bar is available for the return stroke of the riveting module. (see  technical data)

5. Getting Started

- Connect the pneumatic hose PUN-4 to the push-in fittings (1) of the riveting module.
- Connect the pneumatic hose PUN-4 to the operator-side pneumatic control unit.

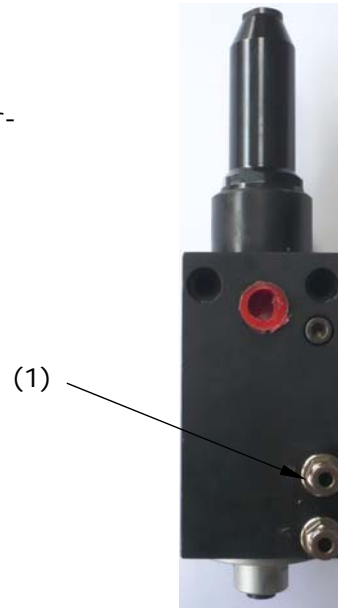

5.3.2 Connect Pneumatic Hoses (Vacuum nozzle / operator pneumatic control)

CAUTION

The pneumatic hoses must not be placed near heat sources or in environments with intense conditions. Ensure that the pneumatic hoses are not kinked, crushed or otherwise damaged!

The mandrel extractor is to be connected to the module by means of a rivet mandrel discharge hose. The pressure regulator for the vacuum nozzle must be connected to the air supply.

- ▶ Connect the rivet mandrel discharge hose (1) to the vacuum nozzle and to the rear connection of the riveting module.
- ▶ Connect the vacuum nozzle (2) to the pressure regulator (3) with the pneumatic hose PUN-8 blue
- ▶ Connect the pressure regulator (3) with the pneumatic hose PUN-8 black to the operator-side pneumatic control unit.

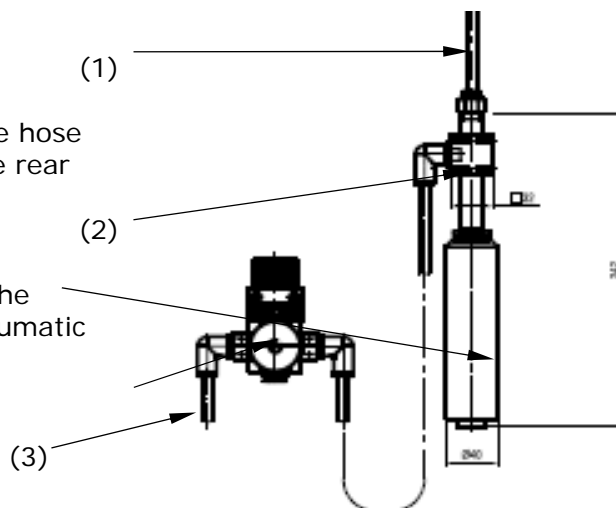

5. Getting Started

5.3.3 Hydraulic Connector

CAUTION

The supply lines must be designed for the maximum system pressure and must (➔ Technical data) be designed to ensure a sufficient flow of operating fluids!

Ensure that the pneumatic hoses are not kinked, crushed or otherwise damaged!

The riveting module and the pressure intensifier must be connected to the hydraulic hose with a coupling plug / coupling socket.

Riveting module assy. Article No.
RK-P3MBx105-1

Hydraulic hose article no. RK-P3MBx105-5

qPressure Intensifier cpl.
RK-P3MBx105-3

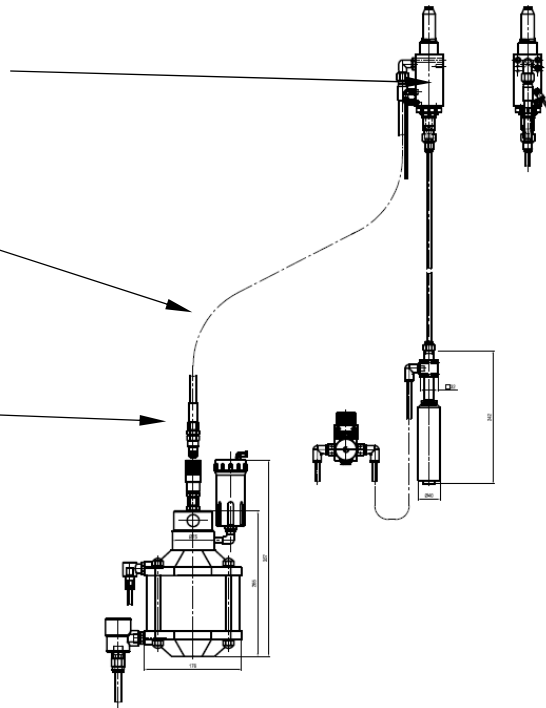

5. Getting Started

Connect hydraulic hose

- Connect the hydraulic hose to the fitting (1) of the riveting module

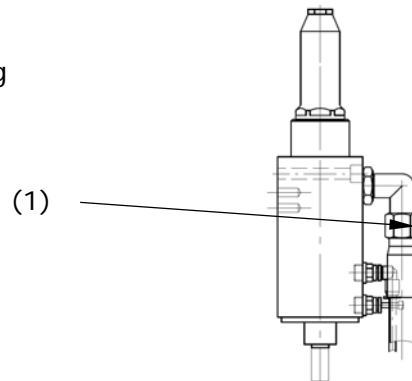

- Insert the coupling plug (2) into the socket (3) of the intensifier

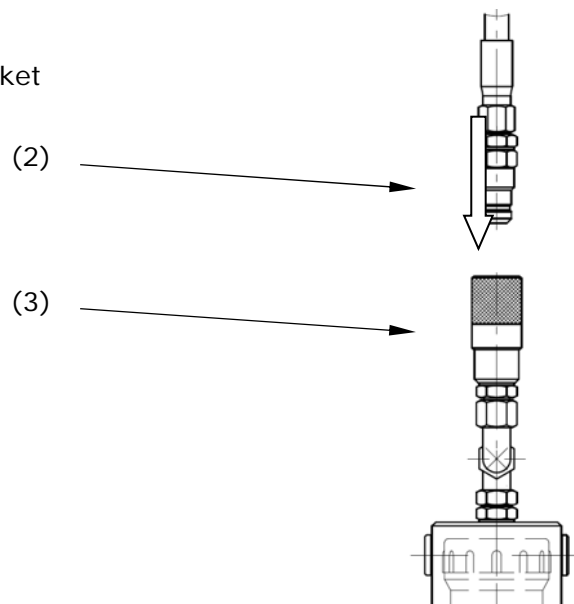

- De-aerate the hydraulic circuit



Drain hydraulic circuit → 7.3 maintenance

The hydraulic hose with coupling plug has already been installed and de-aerated when the riveting module is delivered.

5.4 Setup

Industrial Rivet & Fastener supplies the riveting module for integration into a work process, the structure and sequence of which is determined by the operator. The operator of the complete system is responsible for setting up the riveting module into the overall system.

5. Getting Started

CAUTION	<i>Installation work is to be carried out only by appropriately trained and instructed specialists!</i>
WARNING	<p>Please observe the following points before operation! Failure to do so could lead to personal injury and damage to property!</p> <ul style="list-style-type: none">▶ <i>Make sure that the hydraulic circuit is de-aerated.</i>▶ <i>Make sure that the entire system is connected to a properly working air supply.</i>▶ <i>Make sure that a protective device (guard) is installed.</i>▶ <i>Make sure that the hydraulic hose is connected to the pressure intensifier.</i>▶ <i>Make sure that the pneumatic hoses are connected to the pneumatic control unit.</i>▶ <i>Make sure that the oil level is sufficient in the oil reserve tank of intensifier.</i>

5.4.1 Establish intensifier

NOTICE	<p><i>Check the oil level of the intensifier before initial operation!</i> <i>Failure to do so may result in damage!</i></p>
---------------	--

The integration and operation of the intensifier in the assembly stage is carried out by the operator.

Oil level

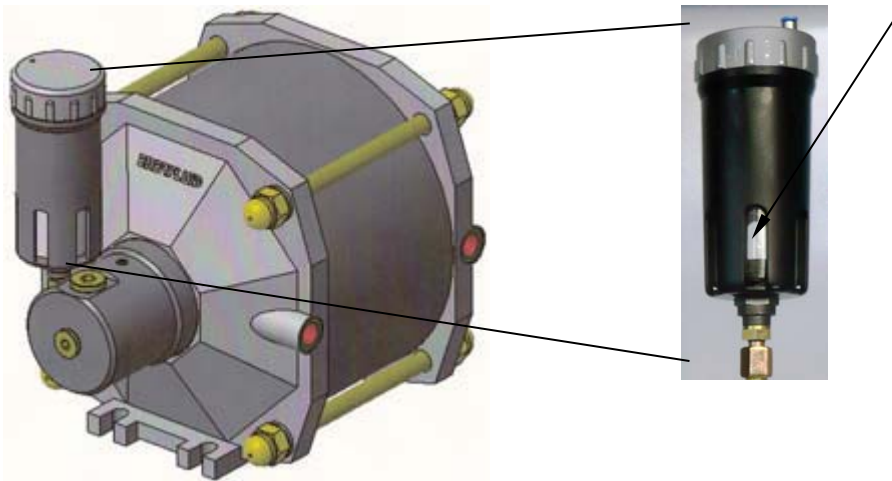

The oil reserve tank of the intensifier must be filled 2/3.

For further information see the operating instructions.

i	Operating instructions Pressure intensifier ↪ 10.1 external documentation
----------	--

5.4.2 Control

The pneumatic control of the riveting module, as well as of the intensifier is carried out by the operator of the overall system.

6. Operation

	<p><i>The riveting module is an incomplete machine as defined by Directive 2006/42 / EC. The riveting module is intended to be installed within a complete installation or other incomplete machinery.</i></p> <p><i>Operation is prohibited until conformity to Directive 2006/42 / EC and all other directives applicable to the installation in which the riveting module has been installed has been confirmed!</i></p>
---	---

6.1 Operation

Industrial Rivet & Fastener supplies the riveting module for integration into a work process, the structure and sequence of which is determined by the operator of the system. The starting signal for the riveting of the riveting module is configured by the operator of the overall system. A description of the operation is therefore not possible.

	<p><i>The operation of the overall system must be carried out only by suitably trained and instructed personnel!</i></p>
---	--

	<p><i>When in the area and during operation of riveting module, eye protection must be worn.</i></p>
---	--

	<p><i>Safety gloves must be worn when working with sharp-edged components.</i></p>
--	--

6.1.1 Riveting module operation

	<p><i>Before the riveting module may be put into operation, be sure to observe the following points!</i> <i>Non-observance can cause injury and damage!</i></p> <ul style="list-style-type: none">▶ <i>Make sure that the conformity of the entire installation has been established and confirmed with Directive 2006/42 / EC and all other applicable directives!</i>▶ <i>Make sure that the hydraulic circuit is de-aerated.</i>▶ <i>Make sure that the entire system is connected to a properly working air supply.</i>▶ <i>Make sure that a protective device (guard) is installed</i>▶ <i>Make sure that the hydraulic hose is connected to the pressure intensifier.</i>▶ <i>Make sure that the pneumatic hoses are connected to the pneumatic control unit.</i>▶ <i>Make sure that the oil level in the oil reserve tank of intensifier is sufficient.</i>
---	--

After checking these points, the complete system can be put into operation with the riveting module.

6. Operation

6.1.1 Riveting module put into operation

- Open the shut-off valve of the main air supply of the customer-supplied maintenance unit. (Production of compressed air supply)

6.1.2 Riveting module decommission

- Close the shut-off valve of the main air supply of the customer-supplied maintenance unit. (Interrupt air supply).

6.2 Operation

Industrial Rivet & Fastener supplies the riveting module for integration into a work process, the structure and sequence of which is determined by the operator of the system. A description of the operation is therefore not possible.

	<p><i>Ensure that sequential riveting is carried out only after the current rivet mandrel has fallen into the rivet mandrel waste container! Failure to do so can lead to property damage and malfunctions!</i></p>
---	---

	<p><i>Risk of injury</i> <i>Protective devices (protective hood) must always be checked by the operator for proper installation, function, and operational safety before operating the system.</i> <i>Failure to do so could lead to personal injury and damage to property!</i></p>
--	---





	<p><i>The following safety instructions must be observed during operation and any handling of the riveting module!</i> <i>Failure to comply can lead to injury.</i></p> <ul style="list-style-type: none">• <i>Do not use rivet application during riveting!</i>• <i>The riveting module must not be operated without the protective hood!</i>• <i>The operating pressure must not exceed 6 bar.</i>• <i>The riveting module must not be operated without complete rivet equipment.</i>
---	--

6.2.1 Operation process

1. Insert the rivet by hand into the rivet module
2. Press the rivet release to begin riveting.
3. Waste mandrels will fall into the rivet mandrel waste container.

7. Maintenance

7.1 Maintenance intervals

 <p>WARNING</p> 	<p><i>Prior to any repair or maintenance work, the riveting module must be disconnected from all supply lines and prevented from turning on!</i></p> <p><i>Failure to comply may result in personal injury.</i></p>
 <p>CAUTION</p>	<p><i>All maintenance and repair work must only be carried out by suitably trained personnel!</i></p>
	<p><i>Worn jaws will no longer grip the mandrel and can lead to operational difficulty.</i></p> <p><i>Maintenance / failure / replacement parts → Equipment Exchange</i></p>

Rivet equipment article no. RK-P3MBX105-1

Pos. - Nr.	Item No.	Description	Number	Comments
1	RK-P3MBX105-NP4.8	Mouth Piece	1	
2	RK-P3MBX105-27	Nose Casing	1	
3	RK-P3MBX105-22	Chuck Collet/Jaw House	1	
4	RK-P3MBX105-21	Chuck Jaws	1	
5	RK-P3MBX105-25	Spreader	1	
6	RK-P3MBX105-23	Buffer Disc	1	
7	RK-P3MBX105-24	Spring	1	
8	RK-P3MBX105-28	Clamping Ring	1	
9	E 020 000 613-20	O-Ring	1	

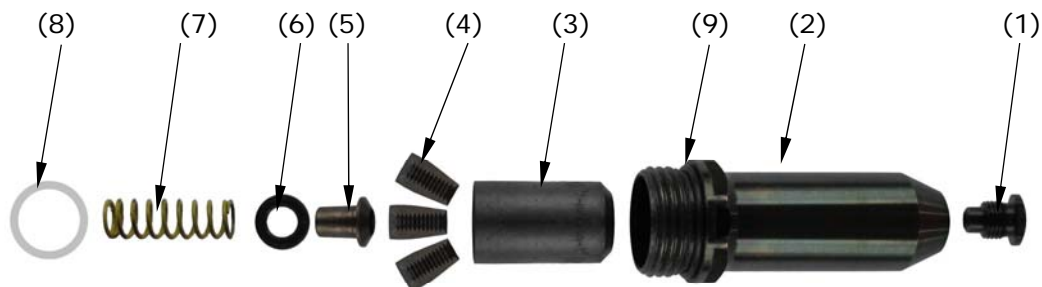

7. Maintenance

7.1 Maintenance intervals

Frequency	What	How	Where	What
Weekly	Riveting Equipment	<input type="checkbox"/> Check clamping JAWS <input type="checkbox"/> Clean and grease clamping jaws and replace if necessary <input type="checkbox"/> Clean and grease jaw housing and replace if necessary <input type="checkbox"/> Check the spring and replace if necessary <input type="checkbox"/> Check the chuck spreader and replace if necessary <input type="checkbox"/> Clean and lubricate the mouthpiece	Pos.4 Pos.4 Pos.3 Pos.7 Pos.5 Pos.1	Cold Cleaning, Moly – lithium grease Cold Cleaning, Moly – lithium grease Cold Cleaning, Moly – lithium grease
Monthly	Pressure Intensifier	► Check the oil level of intensifier and adjust as necessary. (Pressure intensifier 10.1 third-party documentation)		Hydraulic oil DIN EN ISO 6743-4 HLP32
Annually or 500,000 strokes	Riveting module	<input type="checkbox"/> Complete review of annual check by manufacturer		



When working with cleaners, always observe the safety data sheet and the manufacturer's instructions!

7. Maintenance

7.2 changing of the riveting equipment

⚠ WARNING	<i>Prior to any repair or maintenance work, the riveting module must be disconnected from all supply lines and prevented from turning on!</i>
	<i>Failure to comply may result in personal injury.</i>
⚠ CAUTION	<i>All maintenance and repair work must only be carried out by suitably trained personnel!</i>

Changing of the riveting equipment is divided into four steps:

Step 1

- ▶ Use the wrench SW 26, to loosen the nose piece (2) from the mouth piece (1) counter clockwise.



Step 2

- ▶ Carefully pull the nose piece (2) forward off of the mouthpiece (1).



Step 3

- ▶ Using the open-end wrench (SW11/16"), loosen the jaw housing (3) in a counter-clockwise direction.
- ▶ Hold the guide bush (10) with an open-ended spanner SW17.

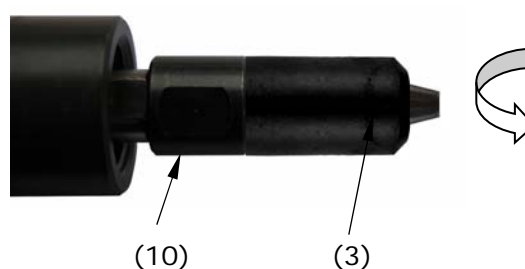

7. Maintenance

Step 4

- ▶ Carefully remove the jaw housing (3), the clamping JAWS (4), the jaw pusher (5), the spring (7), and the buffer (6).
- ▶ Check all components of the rivet equipment.
- ▶ Replace damaged or worn parts.
- ▶ After replacing the necessary parts, reassemble the components in reverse order.

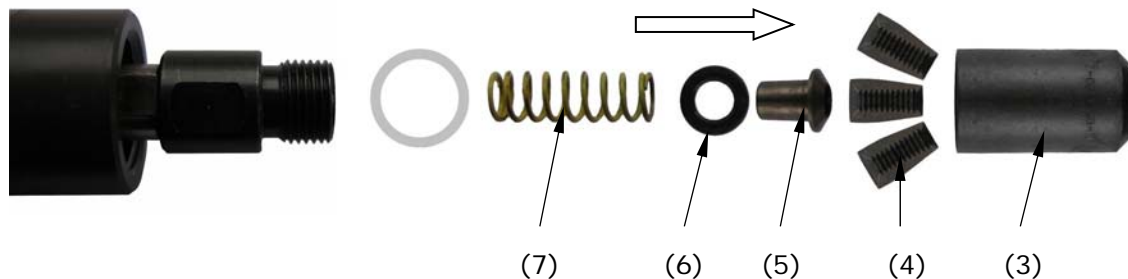

7.3 Venting

<p>⚠ WARNING</p> 	<p><i>Prior to any repair or maintenance work, the riveting module must be disconnected from all supply lines and prevented from turning on!</i> <i>Failure to comply may result in personal injury.</i></p>
<p>⚠ CAUTION</p>	<p><i>All maintenance and repair work must only be carried out by suitably trained personnel!</i></p>
<p>⚠ CAUTION</p>	<p><i>Check the oil level in the sight glass of the oil reserve tank (2) prior to beginning the ventilation process and replenish if necessary.</i></p>
<p>NOTICE</p>	<p><i>Hydraulic oils and lubricants are a threat to ground water. Uncontrolled drainage or improper disposal are punishable by law! ➔ UmweltHG</i></p>

7. Maintenance

The venting of the riveting module is divided into four steps:

1. Step

- ▶ Disconnect the riveting module from the compressed air supply (operating pressure).
- ▶ Apply compressed air (approx. 2 bar) to the upper pressure connection (return stroke) (3) until the compressed air piston of the pressure translator has moved to the home position (A).

2. Step

- ▶ Once the pneumatic piston is in the home position, pressurize the oil reserve tank with 0.7 bar Max external compressed air through the ventilation (1).

3. Step

- ▶ Open the bleed screw (4) of the connected riveting modules and wait until bubble-free oil comes out. Close the bleed screw on the oil outlet (watch for the seals). This process is performed one at a time, at each connected riveting module.

4. Step

- ▶ Fill the intensifier with sufficient oil according to the *sight glass* (2) on the oil reserve tank.
- ▶ Remove the external compressed air lines and turn on the pressure intensifier. Resume operation of the riveting module according to the corresponding operating instructions.

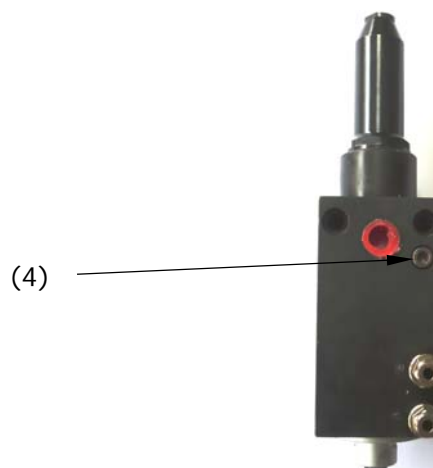
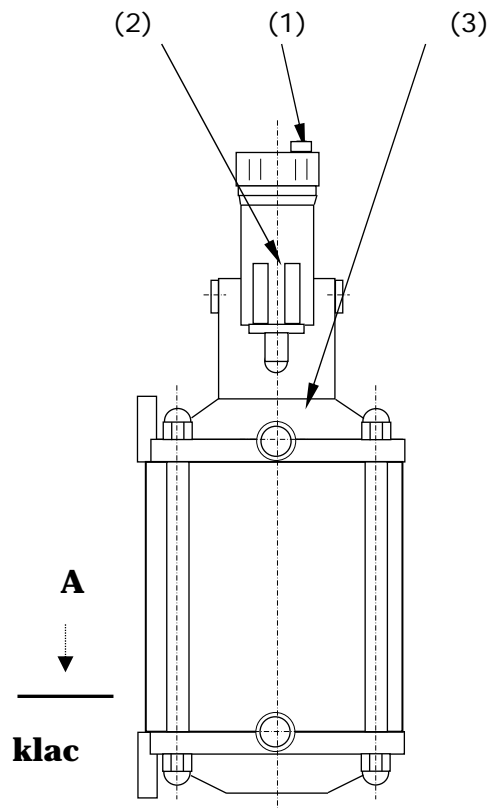

Parts List ➔ 10.1 external documentation - intensifier

7. Maintenance

7.4 Errors

Error	Possible cause (s)	Measure (s)
More than one stroke is required to install the fastener	<p>Leaks in the hydraulic system</p> <p>Insufficient hydraulic pressure</p> <p>Clamping jaws are worn out or broken</p> <p>The oil level of the intensifier is too low or there is air in the oil circuit</p> <p>Dirty equipment</p>	<p>Check the hydraulic line and make sure the riveting module is properly connected. If necessary, replace defective parts</p> <p>Check the settings (➔Technical data) and correct if necessary</p> <p>Remove and replace clamping jaws</p> <p>Check the oil level and, if necessary, fill or vent the system</p> <p>Inspect and clean the equipment</p>
Riveting module does not grip the rivet mandrel	<p>Clamping jaws are worn out or broken</p> <p>Dirty riveting equipment</p> <p>Chuck Collet loose</p> <p>Stretched or broken spring in the equipment</p>	<p>Replace the clamping JAWS</p> <p>Inspect and clean the equipment</p> <p>Chuck Collet tighten</p> <p>Replace spring</p>
Clamping jaws do not release the broken mandrel of the rivet	<p>Dirty equipment</p> <p>Chuck Collet Mouthpiece or mouth piece sleeve incorrectly seated</p> <p>Stretched or broken spring in the equipment</p> <p>Leaks in the oil system</p> <p>The oil level of the intensifier is too low or there is air in the oil circuit</p>	<p>Inspect and clean the equipment</p> <p>Check equipment on correct assembly and correct if necessary</p> <p>Replace spring</p> <p>Check the hydraulic line and make sure the riveting module is properly connected. If necessary, replace defective parts</p> <p>Check the oil level and, if necessary, top up or vent the system</p>
Rivet won't break	<p>Insufficient oil pressure</p> <p>The oil level of the intensifier is too low or there is air in the oil circuit</p>	<p>Check the settings (➔Technical data) and correct if necessary</p> <p>Check the oil level and, if necessary, top up or vent the system</p>

7. Maintenance

In the case of leakages, check the screw connections of the hydraulic hoses and pipes. It is possible that the sealing rings of the riveting unit and of the pressure intensifier must be replaced. After carrying out the work be sure to vent the hydraulic system.

In the case of operating problems or difficulties, please contact your contact person (➔ General data - manufacturer / contact person)

7.5 Spare parts





	<p>Use of spare parts <i>The use of spare parts which are not approved by the manufacturer may lead to consequential damage. Only original spare parts from our spare part list or spare parts approved by Industrial Rivet & Fastener for the riveting module can be used. Failure to comply can lead to personal injury.</i></p>
---	--

To optimize the availability of parts for maintenance and repair work, you should hold the articles below in accordance with the demand index on the spot.

Article No.	Description	Classification	Qty
RK-P3MBX105-NP4.8	Mouth Piece	Spare part	1
RK-P3MBX105-27	Nose Casing	Spare part	1
RK-P3MBX105-22	Chuck Collet/JawHouse	Spare part	1
RK-P3MBX105-21	Chuck Jaws	Consumable	2
RK-P3MBX105-25	Spreader	Consumable	2
RK-P3MBX105-23	Buffer Disc	Consumable	2
RK-P3MBX105-24	Spring	Consumable	2
RK-P3MBX105-26	Clamping Ring	Consumable	2
ISO 6743-4 HLP32	Hydraulic Oil	Consumable	5 Liter

7. Maintenance

7.5.1 Riveting module spare parts Article No.: RK-P3MBX105-1

 <p>WARNING</p> 	<p><i>Prior to any repair or maintenance work, the riveting module must be disconnected from all supply lines and prevented from turning on!</i> <i>Failure to comply may result in personal injury.</i></p>
 <p>CAUTION</p>	<p><i>All maintenance and repair work must only be carried out by suitably trained personnel!</i></p>
 <p>WARNING</p>	<p><i>Risk of injury</i> <i>Risk of property damage</i> <i>Do not exceed the maximum instructed pressure for the riveting module supply lines.</i></p>

Article number	RK-P3MBX105-1
Operating pressure (pneumatic) (backstroke)	Max. 6 bar
Operating pressure (hydraulic)	Max. 320 bar
Mass	approx. 1.2 kg
Piston stroke	Max 21 mm
Oil volume	16 cm ³
Hydraulic oil	DIN EN ISO 6743-4 HLP32
Sound level	< 75dB (A) at 1m distance

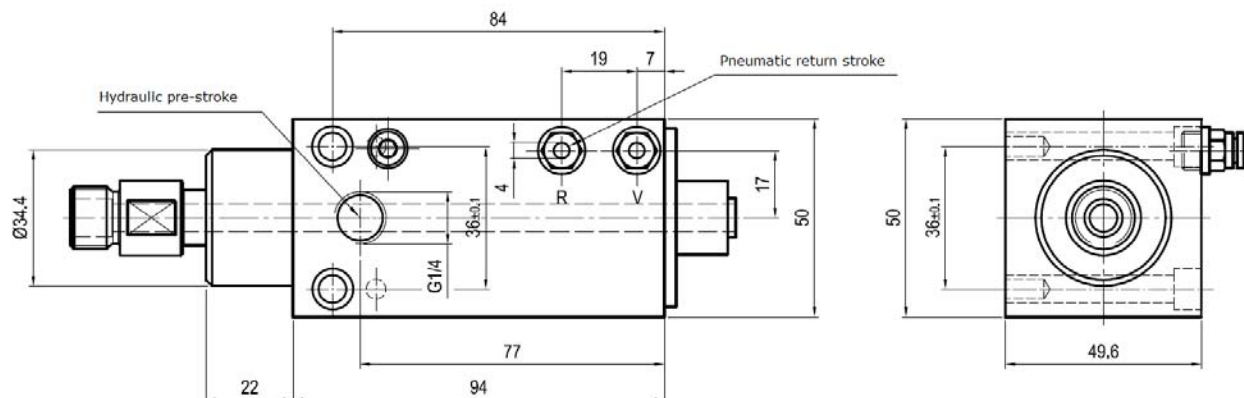

7. Maintenance

7.5.2 Riveting module spare parts Article No.: K 010 000 373

Replacement parts list for riveting module Article No. : K 010 000 373

POS.	Piece	Naming	Article No.
1	1	Housing	RK-P3MBX105-975
2	1	End piece	RK-P3MBX105-919
3	1	Wiper ring	RK-P3MBX105-918
4	1	Hydraulic piston	RK-P3MBX105-916
5	1	Guide bushing	RK-P3MBX105-917
12	1	Rod seal	RK-P3MBX105-216
13	1	Piston seal	RK-P3MBX105-895
14	1	Sealing ring	RK-P3MBX105-896
15	1	Buffer	RK-P3MBX105-897
16	1	End stop	RK-P3MBX105-995
17	2	O ring	RK-P3MBX105-898
18	2	Screw	RK-P3MBX105-996
19	2	O ring	RK-P3MBX105-899
20	1	Bleed screw	RK-P3MBX105-048
21	1	Sealing ring	RK-P3MBX105-049

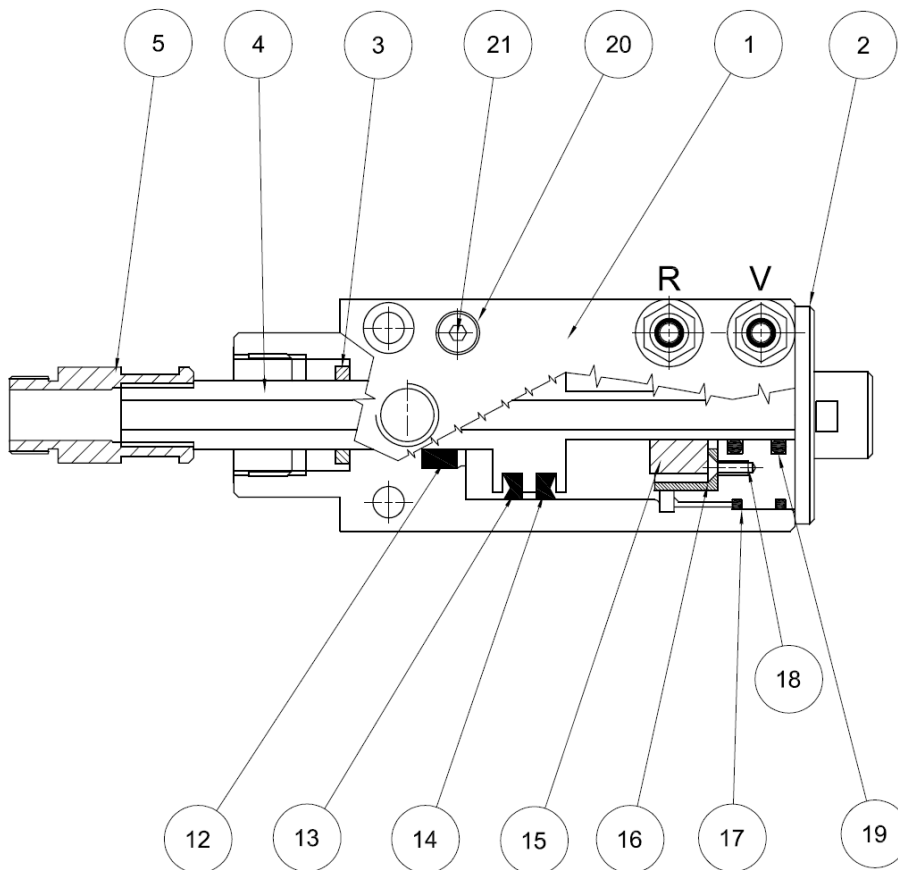

8. Disposal

8.1 Rules

When disposing of the riveting module or its individual components, the applicable legal regulations of the country of use must be observed.

For the scope of Germany, we refer in particular to the following provisions:

KrW-/AbfG



Recycling and waste law

AltöIV



Used oil regulation

UmweltHG

Environmental liability law

Management

Waste management specialist operating regulation¹

¹ complies with Directive 91/156/EEC of 18 March 1991

8.2 Procedure

The individual components of the riveting module must be disposed of separately. First the supplies must be drained and disposed of appropriately by qualified and approved inspection personnel.

NOTICE	<i>Hydraulic oils and lubricants are a threat to ground water. Uncontrolled drainage or improper disposal are punishable by law! ➔ Environmental HG</i>
---------------	---

The remaining components of the riveting module are to be disposed of in accordance with the applicable regulations.

To prevent environmental damage, we recommend that disposal be carried out by authorized specialist companies. ➔ Management

A blue square icon with a white lowercase letter 'i' inside.	<i>A return to Industrial Rivet & Fastener is not permitted!</i>
--	--

Industrial Rivet & Fastener fulfills the following requirements for its products

- the basic responsibility on waste prevention
- the basic responsibility of waste recycling
- the basic responsibility of waste disposal

8.3 Further

For further questions regarding the current legal situation regarding proper disposal and environmental protection, please contact your designated waste disposal company.

9. Certificate

Declaration of incorporation of partly completed machinery (Machinery directive 2006/42/EC)

Manufacturer:

Industrial Rivet & Fastener
200 Paris Avenue
Northvale, New Jersey 07647

CE documentation of representative

Steven Sherman
200 Paris Avenue
Northvale, New Jersey 07647

We hereby declare that the following incomplete machine:

Name of the product : **Riveting Module**

Type designation : **RK-P3MBX105**

Article number: **RK-P3MBX105**

Year of constr.: **2017**

Complies with the following basic requirements:

- ▶ 1.1.2, 1.1.3, 1.1.5, 1.1.6
- ▶ 1.2.6
- ▶ 1.3.2, 1.3.4
- ▶ 1.5.3, 1.5.6, 1.5.7
- ▶ 1.6.1, 1.6.2
- ▶ 1.7.2, 1.7.4

The technical documentation referred to in Annex VII, Part B has been compiled. An authorized representative is obliged to submit these product documents to the competent authority on request.

Operation is prohibited until the above mentioned machine complies with the provisions of the Machinery Directive.

Industrial Rivet & Fastener Co. 08.06.2017...

Place, date of issue

Managing Director

9. Certificate

Assembly instructions pursuant to annex VI

(Machinery directive 2006/42/EC)

The riveting module must be assembled into a complete machine.

➤ **Mechanical Hazards**

The riveting module must be integrated into the overall system in such a way that the area above the module is covered by a protective device (eg. protective hood made of transparent polycarbonate).

The protective device must cover the riveting application and must be installed by the operator of the overall system. Operation of the machine without a protective device is prohibited.

Installation can only be carried out by qualified persons.

➤ **Pneumatic Hazards**

Pneumatic connection of the module must be completed by the operator of the overall system.

The pneumatic hoses must not be placed near heat sources or in dangerous environments.

Ensure that the pneumatic hoses are not kinked, crushed or otherwise damaged!

Connection can only be carried out by qualified persons.

➤ **Hydraulic Hazards**

Pneumatic connection of the module must be completed by the operator of the overall system.

The supply lines must be designed to handle the maximum system pressure and ensure a sufficient flow of the operating fluids!

Make sure the hydraulic system is de-aerated.

Ensure that the hoses are not kinked, crushed or otherwise damaged.

Connection can only be carried out by qualified persons.

➤ **Stability of the full machine**

The riveting module must be mounted on a stable base frame using the existing mounting holes.

➤ **Site selection of the riveting module**

Sufficient space with access for maintenance and repair of the riveting module should be considered when selecting a site.

10. Third-Party Documentation

10.1 Intensifier

Manufacturer	ENERFLUID Sede legal Via Gavardina Sopra Trav.I nr. 5 25010 Ponte san Marco BS Italia
Type:	Operating instructions
Name:	Pressure intensifier
ID:	E 020 000 550 type 160.25.05 RP
Format:	DIN A4
Ingredients:	10 pages
Comments:	-/-

Operating Instructions



160/25/05 RP

**Pneumatic hydraulic
Pressure intensifier**

Safety instructions

The following safety instructions are included and must be followed during the installation, operation, and maintenance of the pressure intensifier!

- 1** Do not use any equipment other than Industrial Rivet & Fastener recommended and supplied spare parts and equipment.
- 2** The device must be maintained in such a way that it always complies with the applicable safety standards and ensures safe operation.
- 3** Before any repair or maintenance work on the pressure intensifier, ensure that the control unit cannot turn back on.
- 4** The pressure translator must comply with the applicable accident prevention and safety regulations at all times. Please contact Industrial Rivet & Fastener for any questions concerning plant and user safety.
- 5** Make sure that ventilation devices are not covered or clogged.
- 6** Technical modifications to the device which have not been carried out or expressly confirmed in writing by Industrial Rivet & Fastener will lead to liability and guarantee limitations.
- 7** Before of any repair or maintenance work of hydraulic components, connecting cables must be depressurized.
- 8** Before of any repair or maintenance work on the pneumatic components connecting cables must be disconnected from the compressed air supply.
- 9** The pressure intensifier must only be operated by suitably trained personnel while observing any and all relevant accident prevention regulations!
- 10** These operating instructions must be kept on site with the intensifier and be legible and accessible to the operator.

General data

WARRANTY/LIABILITY

The **general terms and conditions** of Industrial Rivet & Fastener apply. These are available to the customer when the contract is concluded. Warranty and liability claims for personal injury and property damage are excluded if it is attributable to one or more of the following causes:

- Improper installation, operation, or maintenance of the intensifier.
- Operation of the intensifier despite defective, improperly mounted or non-functional safety equipment.
- Structural alteration without express written confirmation by Industrial Rivet & Fastener Co.
- Inadequate monitoring of parts that are subject to wear.
- Improperly carried out repairs or maintenance.
- Accidents due to exposure to a foreign body or excessive force.

OBLIGATIONS OF THE OPERATOR

The operator is required to

- Only allow persons to work with the pressure intensifier who are familiar with the basic regulations of work safety and accident prevention and who are trained in the handling of the system.
- Provide the required personal protective equipment for the operating personnel.
- Periodically review the existing safety and protection devices.
- Ensure that the operating personnel are informed of the operating instructions, in particular the safety regulations and warnings.

OBLIGATIONS OF THE OPERATOR

The staff of the plant are required to

- Know the basic regulations regarding safety at work and accident prevention.
- To read the operating instructions, in particular the safety and warning instructions.
- Report damage to the intensifier or system immediately.

SUPPLIER/PARTNER

Supplier of the intensifier is:

Industrial Rivet & Fastener Co.

200 Paris Avenue, Northvale NJ 07647

Phone 201-750-1040

Fax 201-750-1050

Email info@rivet.com

Manufacturer of the intensifier is:

ENERFLUID

Sede legal

Via Gavardina Sopra Trav.I nr. 5

25010 Ponte san Marco BS Italia

Device description

OPERATION

The 160/25/05 RP pneumatic-hydraulic pressure intensifier converts a low pneumatic pressure on the primary side into a higher hydraulic pressure on the secondary side. This operation makes it possible to operate a hydraulic load (e.g., cylinder) with higher hydraulic pressure by means of the relatively low pneumatic operating pressure.

The structure is characterized by a piston / cylinder combination in which a pressure transmission is produced by pressurizing surfaces of different sizes. On the secondary side, the high pressure is regulated directly proportional to the primary low pressure. The pressure translator 160/25/05 RP operates with a ratio ratio of 1:41. If it is primarily pressurized with approx. 6 bar of compressed air, this is converted to approx. 246 bar oil pressure on the secondary side.

Technical Data

Operation	Pneumatic-Hydraulic
Area Ratio	1:41
maximum operating pressure (pneumatic)	6 bar
Fuel type and type of hydraulic oil	ESSO Nuto H68

Dimensions:

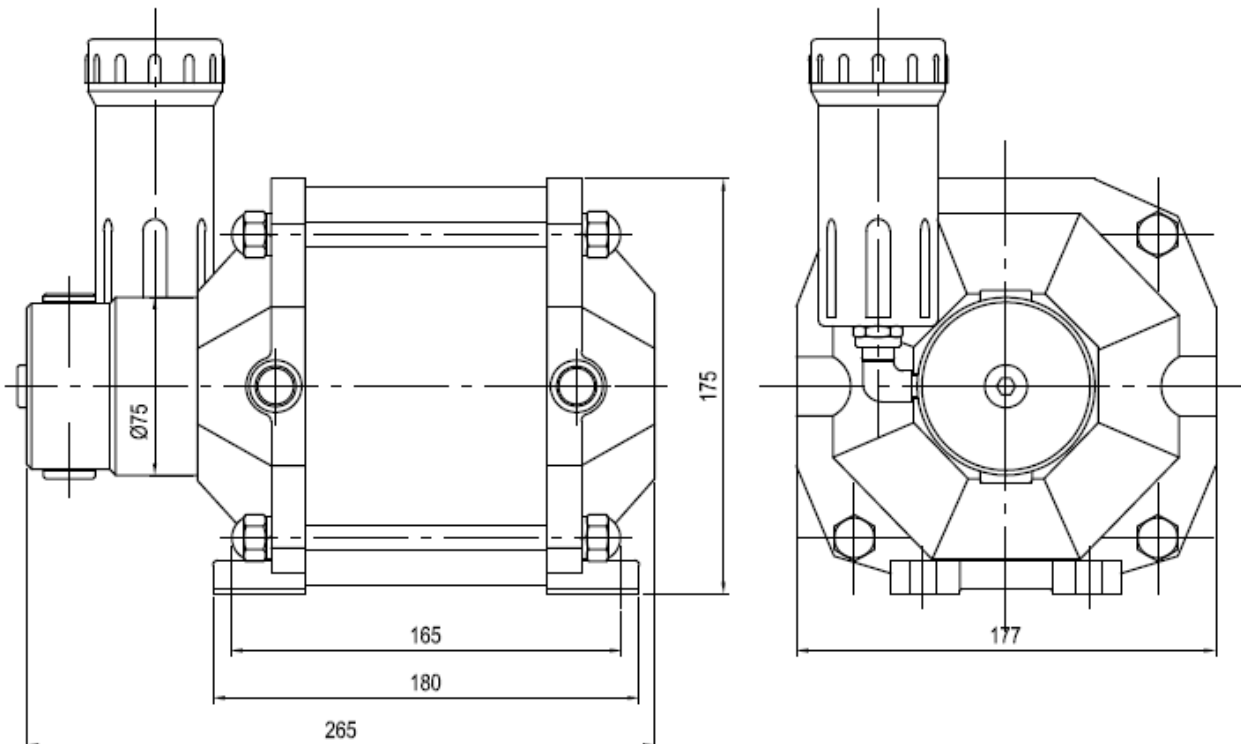

CONSTRUCTION / SPARE PARTS

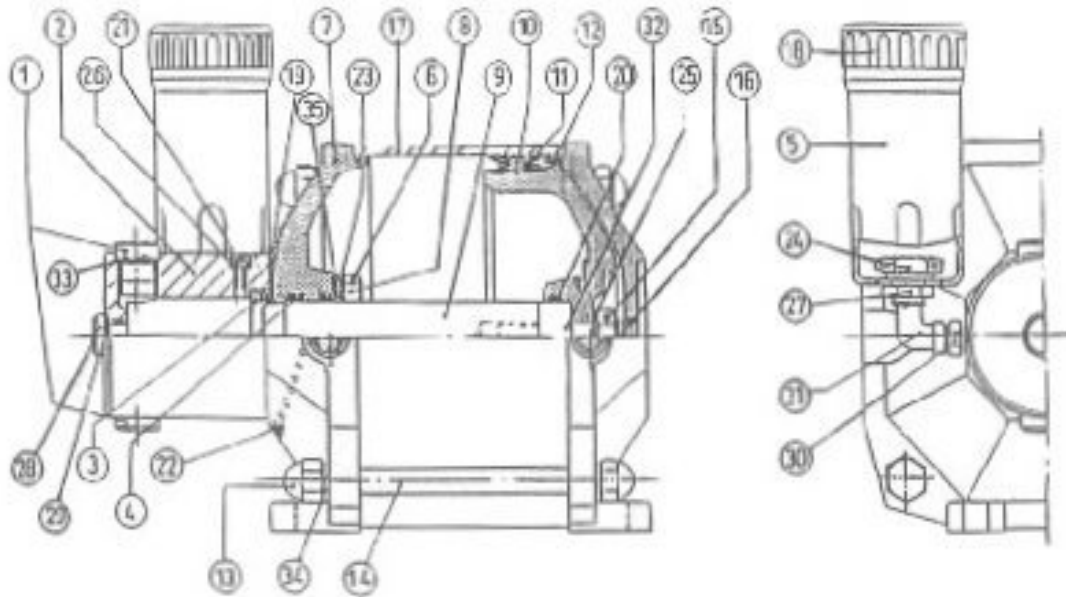

Pos.	Beschreibung	Menge
1	3/8" Plugs	2
2	Head	1
3	O-Ring	1
4	Fitting	1
5	Oil reserve tank	1
6	Hexagonal nut	4
7	Front cover	1
8	Seal	1
9	Piston rod	1
10	Piston	1
11	Piston Seal	2
12	Rear flange seal	2
13	Cap nut with elastic seal	8
14	Pin	4
15	Mother	1
16	Rear flange	1
17	Air cylinders	1
18	Lid	1
19	Head gasket	1
20	O-Ring	1

CONSTRUCTION / SPARE PARTS

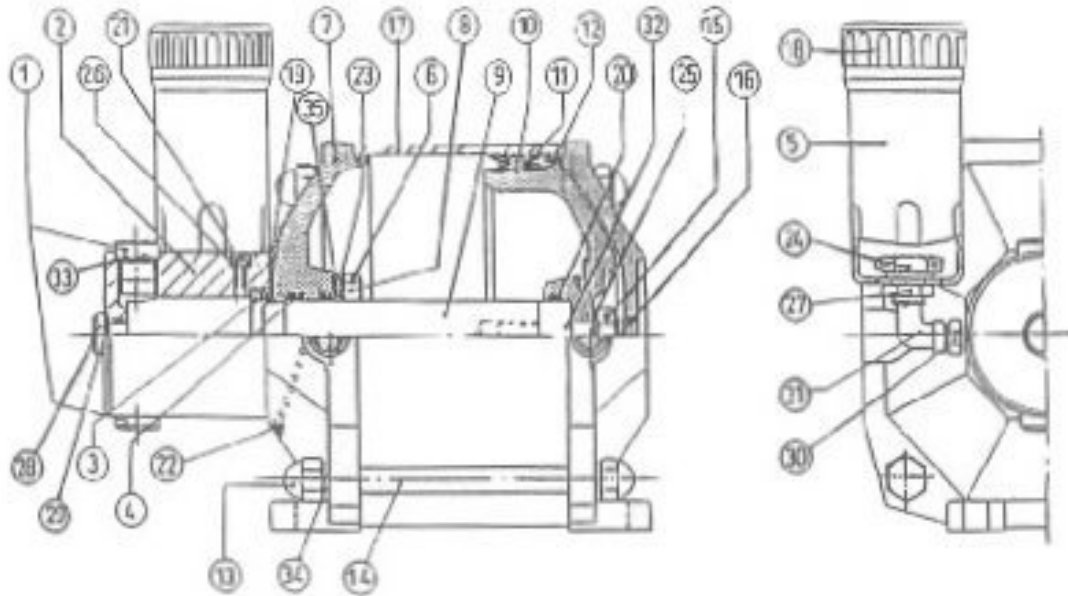

POS	Description	Lot
21	Bleed screw	1
22	Filter	1
23	Disc	4
24	Connection	1
25	Disc	1
26	Seal	1
27	Mother	1
28	Blanking Plug	1
29	Sealing washer	1
30	Screw connection	1
31	Angle	1
32	Usage	1
33	Disc	2
34	Retaining ring	8
35	Aluminum seal	4

Operation

ASSEMBLY

The 160/25/05 RP pressure intensifier can be installed horizontally in three installation positions (nine, twelve, and three o'clock) and vertically with the hydraulic part pointing downwards.

When mounting in a horizontal mounting position, make sure that the bleed screw (see chapter Description of the device - assembly / spare parts) is directed upwards.

The pressure intensifier has an oil reserve tank, see the chapter "Description of the device - assembly / spare parts"), which ensures an even oil supply in the transmission system. The system is automatically vented.

For the assembly of the supply lines, the following are required for the 160/25/05 RP connections provided:

Pneumatic connections G 3/8i
Hydraulic connections G 1/4i

The intensifier 160/25/05 RP is designed only for the connection of single-acting hydraulic cylinders.

The supply lines and screw connections selected for installation must comply with the system requirements and ensure a sufficient flow of the operating fluids!

After assembling all the screw connections and lines, the pressure intensifier has to be filled with the corresponding operating material (see chapter device description - technical data).

- (1) Open the bleed screw (item 21) and fill the oil reservoir tank (item 5) with oil.
- (2) Close the bleed screw (item 21).
- (3) Connect the control circuit for the intensifier to a compressed air supply with sufficient operating pressure (see chapter - device description and specifications).
- (4) Flip the pressure translator back and forth a few times so that the transmission system is filled with oil.
Fill the oil reserve tank (item 5) again.
- (5) If the system is filled with enough oil, check all the bleed screws on the pressure translator as well as on the hydraulic cylinder and possibly other components for leaks and close the oil reserve tank (item 5) with the cover (item 18).

The position descriptions can be found in the section - Device description, Design / Spare parts.

Operation

OPERATING CONDITIONS

Consider the following points to ensure correct operation of the intensifier 160/25/05 RP:

- The air pressure must be sufficient (see chapter device description - specifications).
- The air quantity must be sufficient.
- Supply lines, screw connections, couplings, etc. must be sufficiently dimensioned.
- The length of the supply lines and hoses should be as short as possible.
- Ensure that the system is properly ventilated.

STORAGE/TRANSPORT

Transport data

The dimensions and other data of the 160/25/05 RP is available in the chapter Device description - Technical data.

Transport damage

Upon delivery receipt, the customer should inspect for damage and immediately report any findings.

If transport damage is detected, it must be documented (eg photographed) in such a way that it can be tracked later.

Storage

During temporary storage of the 160/25/05 RP, make sure that the selected storage location is dry. Depending on the expected storage time, delicate parts must be preserved and protected against contamination and damage.

Disposal

REGULATIONS

When disposing of the devices or their components are the valid legal Regulations must be observed. In particular, we refer to the following regulations:



KrW-/AbfG

Recycling and waste law

BattV

Ordinance on the return and disposal of used Batteries and accumulators

UmweltHG

Environmental liability law

DISPOSAL

The individual components of the riveting module must be disposed of separately. First the supplies must be drained and disposed of appropriately by qualified and approved inspection personnel.

Hydraulic oils pose a threat to ground water. Uncontrolled drainage or improper disposal are punishable by law (UmweltHG).

Accumulators and batteries must with particular reference to the legal Provisions be disposed.

Batteries and rechargeable batteries must be disposed of separately from the non-recyclable waste and must not go into household waste.

The remaining components of the installation are to be recycled in accordance with applicable regulations.

For the prevention of environmental damage, we recommend that disposal be carried out by authorized specialist companies. A return to Industrial Rivet & Fastener will not be accepted.

ADDRESSES

For further questions concerning the current legal situation regarding proper disposal and environmental protection, please contact your designated waste disposal company.